



L-1X / L-1X16

Chemical Sanitizing
Undercounter
Dishwasher

MODEL L-1X



MODEL L-1X16

FEATURES:

- **Energy Star Qualified.**
- 30 racks / 120 covers per hour.
- Economical to operate. Uses only 1.7 gallons of water per cycle.
- All stainless steel construction assures long life and years of trouble free operation.
- 16" door opening on the (L-1X16) allows the washing of larger items. (L-1X) door opening 12-1/8".
- Unique spray arm system features upper and lower stainless steel wash arms with reinforced end caps.
- Built-in chemical pumps and delimiting system assures proper chemical usage.
- Convenient to service "Work-in-a-drawer". All electrical components are attached to a sliding drawer for easy access and service.
- Pumped drain allows for flexible installation. Requires no floor drain.
- Pump purging system improves results by eliminating soil and chemical carryover during rinse cycle.
- Stainless steel pump impeller. Offers extended life and service.
- Built-in strainer in water inlet system to prevent water valve from clogging.
- Two dishracks included.
- Built-in primer switches.
- Built-in instant start.
- Door safety switch makes operation safe.



Optional dishtable and faucet.



Pumped drain will drain uphill. Requires no floor drain.

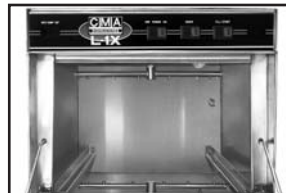

Upper and lower rotating wash arms guarantee excellent results.



"Work-in-a-drawer", may be removed.



The optional Universal Pedestal has a storage feature for spare dishracks, with the ability to store two empty dishracks beneath the machine. 15-1/4"H X 24"W X 25-1/4"D.

Available Options

- Sustainer Heater
- Sanitizer Alarm
- CMA Temp-Sure™ (Self contained 12kW heater)
- Stainless Steel Legs 6" (set of 4)
- Stainless Steel Pedestal
- 48" Undercounter dishtable with Pre-Rinse
- Alternative electrical available for export





L-1X / L-1X16
Chemical Sanitizing Undercounter Dishwasher

WARNING: Plumbing connections must be made by a qualified service company who will comply with all available Federal, State, and Local Health, Plumbing and Safety codes.

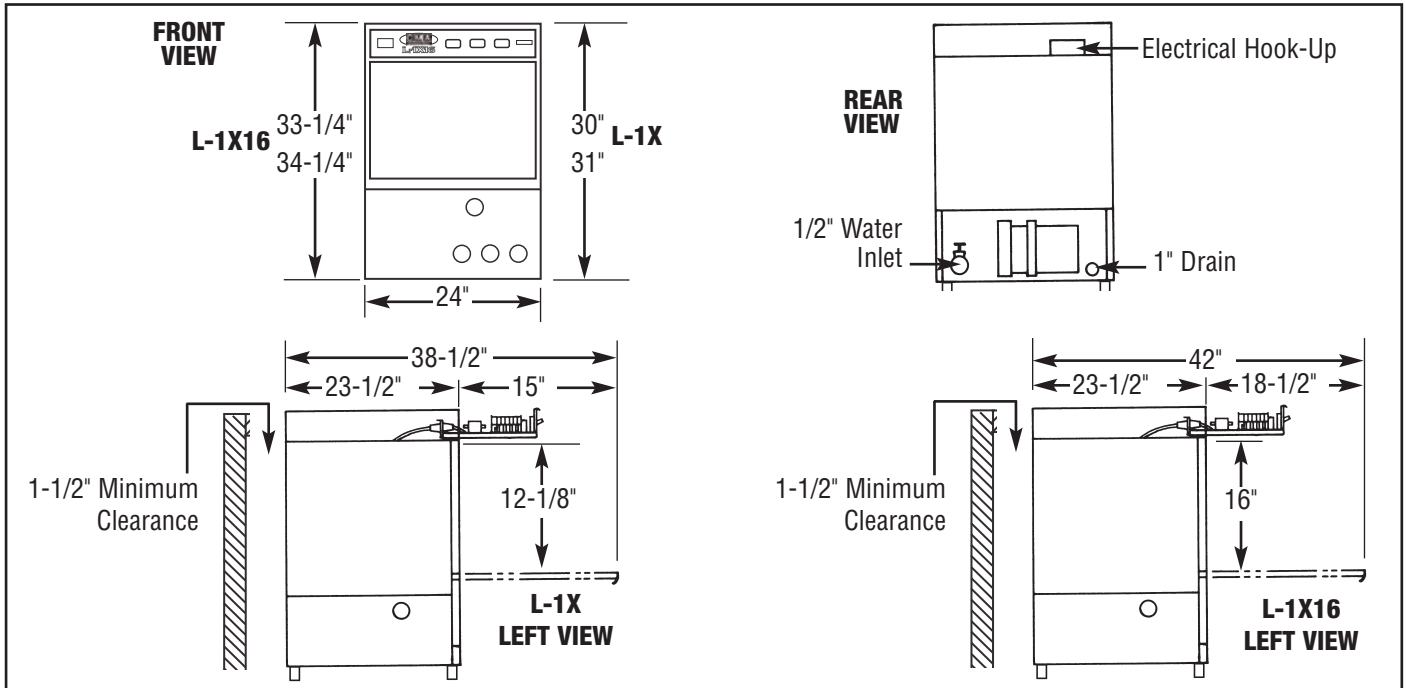

Specifications:

UNDERCOUNTER DISHWASHER	L-1X/L-1X16	USA	METRIC
OPERATING CAPACITY			
RACKS PER HOUR (NSF RATED)	30		
OPERATING CYCLE			
WASH TIME-SEC	57		
RINSE TIME-SEC	48		
DWELL/PURGE-SEC	15		
TOTAL CYCLE TIME	120		
WASH TANK CAPACITY	1.7 GAL.		
WASH PUMP CAPACITY	35 GPM		
OPERATING TEMPERATURE			
REQUIRED	120°F		
RECOMMENDED	140°F		
WATER CONSUMPTION			
PER RACK	1.7 GAL.		
PER HOUR	51 GPH		
WATER INLET	1/2"		
DRAIN	1"		
WASH PUMP MOTORS HP		1	1
DIMENSIONS			
DEPTH		23-1/2"	(59cm)
WIDTH		24"	(61cm)
HEIGHT		33-1/4"-34-1/4" (L-1X16)	(84-86 cm)
HEIGHT		30"-31" (L-1X)	(76.2-78.2 cm)
MAXIMUM CLEARANCE HEIGHT FOR DISHES		16" (L-1X16)	(40.64cm)
MAXIMUM CLEARANCE HEIGHT FOR DISHES		12-1/8" (L-1X)	(31cm)
STANDARD DISHRACK		1	1
DIMENSIONS		19-3/4"X19-3/4"	(50X50cm)
ELECTRICAL RATING		VOLTS	AMPS
		115	16
SHIPPING WEIGHT			
APPROXIMATE		196#	(88kg)

Summary Specifications: Models L-1X / L-1X16

CMA Energy Mizer models L-1X and L-1X16 low temperature undercounter chemical sanitizing commercial dishwashers meets NSF, UL and CUL sanitation and construction standards WITHOUT the use of BOOSTER or TANK HEATERS. The models L-1X and L-1X16 is constructed entirely of stainless steel. Each unit automatically washes, rinses and sanitizes food service utensils in standard 19-3/4"X19-3/4" racks. Units comes standard with upper and lower stainless steel wash arms. The L-1X and L-1X16 incorporates a pump purging system that improves results by eliminating soil and chemical carryover during rinse cycle.

