



UC50e

High Temp Undercounter Dishwasher And Glasswasher



FEATURES:

- **Energy Star Qualified.**
- 30 racks / 120 covers per hour.
- Fully automatic cycle for easy operation
- Built-in detergent and rinse chemical pumps.
- Pump drain allows for multiple installation applications including elevated drains.
- Safety Temp feature assures 180°F sanitizing rinse every cycle.
- Built-in 6 kW booster heater
- 2.7 kW wash tank heater.
- Double skin stainless steel provides consistent heating and a quiet operation.
- Low 0.8 US gal. water usage per rack.
- Door and water level safety switches, plus booster safety thermostat.
- Stainless steel safety filters protect wash pump.
- Polished stainless steel surface and tanks with rounded corners for a total and easy cleaning.
- Operator friendly, removable wash and rinse arms allows for easy cleaning.
- Triple filtering protection system, captures excess soil and debris.

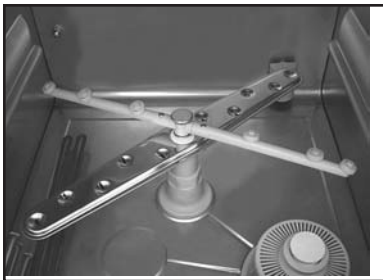

Upper and lower wash and rinse arms guarantee excellent results.



Large 13-3/4" door clearance accommodates oversized plates, glasses and utensils.



Built-in detergent and rinse chemical pumps.



Top mounted controls are easy to read and simple to operate.





UC50e

High Temp Undercounter Dishwasher And Glasswasher

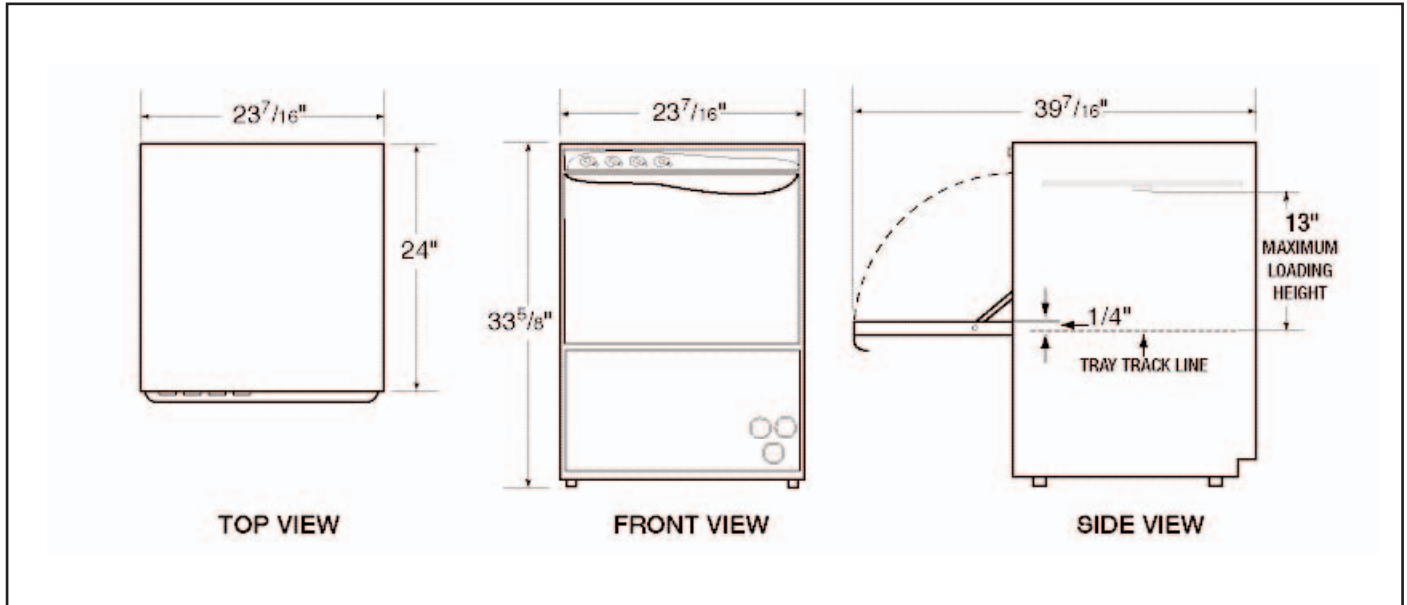

Specifications:

MODEL UC50e	USA	METRIC		USA	METRIC
WATER CONSUMPTION			FRAME DIMENSIONS		
PER RACK	.8 GAL	(3L)	DEPTH	24"	(61 CM)
PER HOUR	24/16 GAL	(90/60L)	WIDTH	23-7/16"	(59.5 CM)
OPERATING CYCLE			HEIGHT	33-5/16"	(84.5 CM)
WASH TIME-SEC	100/160	100/160	MAXIMUM LOADING HEIGHT	13"	(33 CM)
RINSE TIME-SEC	15/15	15/15	STANDARD DISHRACK DIMENSIONS	1	1
DWELL-SEC	5/5	5/5		19-3/4"X19-3/4"	(50X50CM)
TOTAL CYCLE-SEC	120/180	120/180	SHIPPING WEIGHT	165#	75(KG)
OPERATING CAPACITY			WASH PUMP MOTORS HP	3/4HP	
RACKS PER HOUR	30/20	30/20	HEATERS		
WASH TANK CAPCITY	6.87 GAL	(26L)	WASH TEMP HEATER	2.7kW	
WATER REQUIREMENTS			BOOSTER HEATER	6kW	
WATER INLET	140°F	(60°C)	ELECTRICAL RATING (TOTAL AMPERAGE DRAWN)	VOLTS	PHASE
DRAIN CONNECTION	3/4"			208	1
RINSE PRESSURE SET	1"			230	1
CYCLE TEMPERATURES					AMPS
WASH-°F	155°F-160°F	(68°C/71°C)			28
RINSE-°F	180°F-195°F	(82°C/90°C)			30

WARNING: Plumbing connections must be made by a qualified service company who will comply with all available Federal, State, and Local Health, Plumbing and Safety codes.

Summary Specifications:

The UC50e dishwasher and glasswasher is a front loading machine designed to produce sparkling clean glasses and dishes. Constructed of double walled stainless steel skin providing constant heating and a quiet operation. Standard features include upper and lower wash/rinse arms and wash and booster tank heater. Features include 13" maximum loading height, standard liquid detergent rinse-aid dispenser.

KROMO BRANDS

Distributed exclusively by CMA Dishmachines

