



UC60e
High Temp Undercounter
Dishwasher And
Glasswasher



FEATURES:

- **Energy Star Qualified.**
- Total cycles 60/120/180/300 seconds
- 50/30/20/12 racks/hour.
- Fully automatic cycle for easy operation
- Built-in detergent and rinse chemical pumps.
- Pumped drain allows for multiple installation applications including elevated drains.
- Pumped rinse for constant pressure.
- Safety Temp feature assures 180°F sanitizing rinse every cycle.
- Built-in 6.53 kW booster heater
- 2.94 kW wash tank heater.
- Double skin stainless steel provides consistent heating and a quiet operation.
- Low 0.7 US gal. water usage per rack.
- Booster safety thermostat.
- Polished stainless steel surface and tanks with rounded corners for a total and easy cleaning.
- Operator friendly, removable stainless steel wash and rinse arms allows for easy cleaning.
- Triple filtering protection system, captures excess soil and debris.
- Solid state integrated controls with digital status indicators.



Built-in detergent and rinse chemical pumps.



Large 13-3/4" door clearance accommodates oversized plates, glasses and utensils.

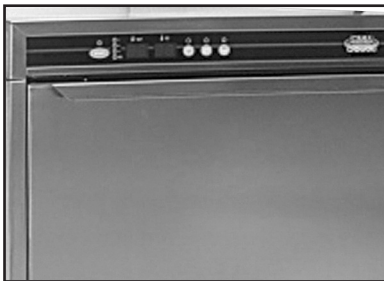

Top mounted controls are easy to read and simple to operate.



Upper and lower wash and rinse arms guarantee excellent results.





UC60e
High Temp Undercounter
Dishwasher And
Glasswasher

WARNING: Plumbing connections must be made by a qualified service company who will comply with all available Federal, State, and Local Health, Plumbing and Safety codes.

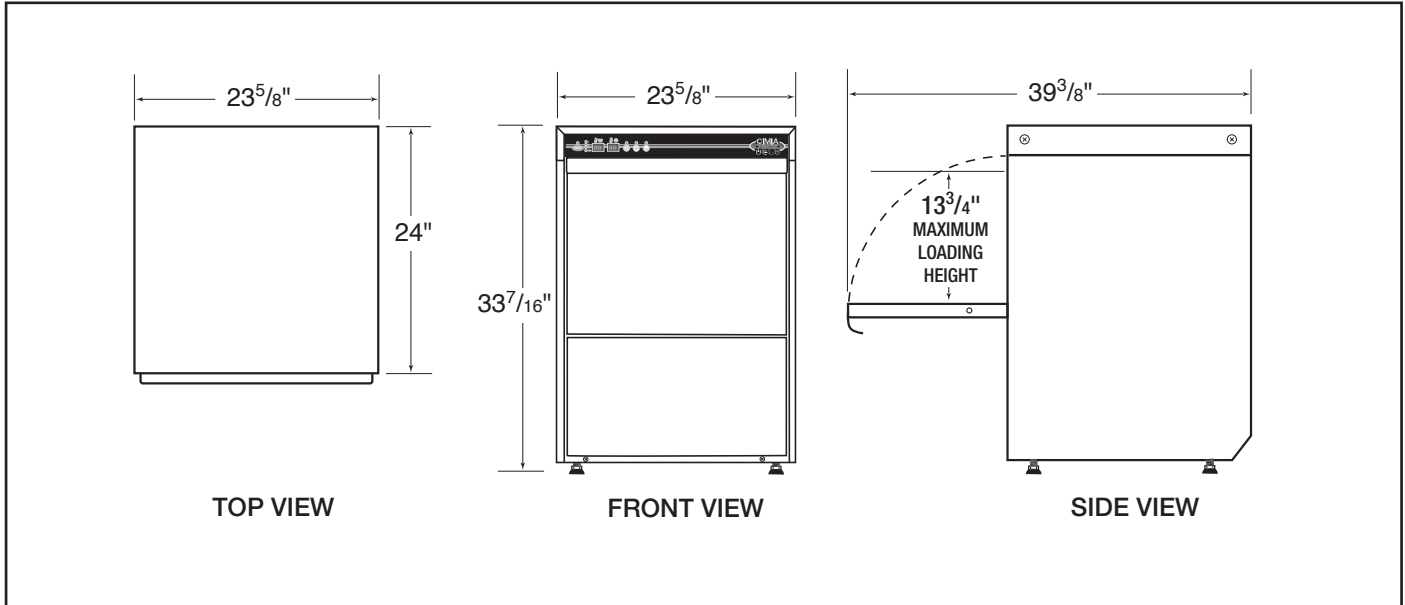

Specifications:

MODEL UC60e	USA	METRIC	USA	METRIC
WATER CONSUMPTION				
PER RACK	.7 GAL	(2.6L)		
PER HOUR	48/21/14/9 GAL	(130/78/52/31L)		
OPERATING CYCLE				
WASH TIME-SEC	40/100/160/280	40/100/160/180		
RINSE TIME-SEC	15	15		
DWELL-SEC	5	5		
TOTAL CYCLE-SEC	60/120/180/300SEC	60/120/180/300SEC		
OPERATING CAPACITY				
RACKS PER HOUR	50/30/20/12	50/30/20/12		
WASH TANK CAPACITY	6.87 GAL	(26L)		
WATER REQUIREMENTS				
WATER INLET	140°F	(60°C)		
DRAIN CONNECTION	3/4"			
RINSE PRESSURE SET	1"			
	25 PSI	1.76kg/cm ²		
CYCLE TEMPERATURES				
WASH-°F	155°F-160°F	(68°C/71°C)		
RINSE-°F	180°F-195°F	(82°C/90°C)		
FRAME DIMENSIONS				
DEPTH	24"	(61 CM)		
WIDTH	23-5/8"	(60 CM)		
HEIGHT	33-7/16"	(85 CM)		
MAXIMUM LOADING HEIGHT	13-3/4"	(35 CM)		
STANDARD DISHRACK DIMENSIONS	1	1		
	19-3/4"X19-3/4"	(50X50CM)		
SHIPPING WEIGHT	165#	75(KG)		
WASH PUMP MOTORS HP	3/4HP	650W		
HEATERS				
WASH TEMP HEATER	2.7kW / 12.94kW			
BOOSTER HEATER	6kW / 16.53kW			
ELECTRICAL RATING	VOLTS	PHASE	AMPS	
	220-240 ± 6%	1	30	
	TOLERANCE TESTED			

Summary Specifications:

The UC60e dishwasher and glasswasher is a front loading machine designed to produce sparkling clean glasses and dishes. Constructed of double walled stainless steel skin providing constant heating and a quiet operation. Standard features include upper and lower wash/rinse arms and wash and booster tank heater. Features include 13-3/4" door opening clearance, standard liquid detergent rinse-aid dispenser.

KROMO BRANDS

Distributed exclusively by CMA Dishmachines

