

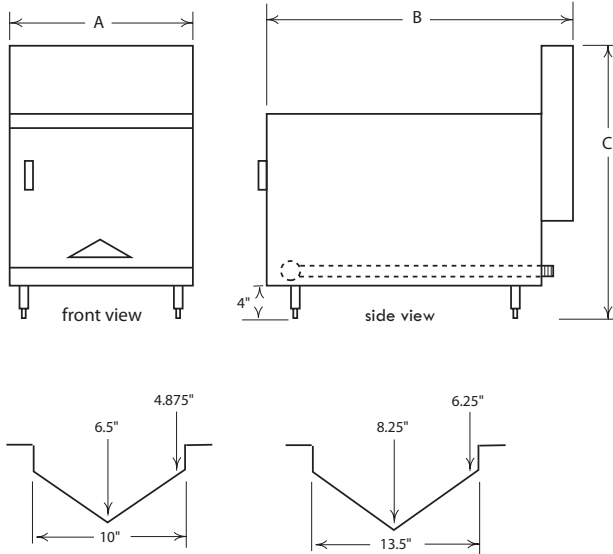

JOB _____ ITEM # _____

COUNTER FRYERS

Models: J01HG & 2616HG



Standard Features, Benefits & Options

CONSTRUCTION: Easy cleaning, corrosion resistant stainless steel finish, welded with aluminized inner framing. Double wall construction with heavy insulation combined with a special flue design for cooler operation. Adjustable 4" stainless steel legs for easy leveling. Installation clearances for non-combustible surfaces are 2" on sides and 6" in the rear, combustible surface clearances are 6" and 6". Hinged front door panel protects controls.

BURNERS: Long life, cast iron "H" pattern burners combined with a special "V" shaped tank design directs heat for superior heat transfer. Model 2616HG features 2 - 20,000 BTU burners, model J01HG features 1 - 18,000 BTU burner.

CONTROLS: Snap Action thermostat for fast recovery, 100% safety shut off, high limit control for back-up safety, automatic standing pilot and brass burner valves. Pressure regulators are set at the factory for natural gas and easily convertible to propane. Optimal pressures are 4" WC for natural gas and 10" WC for propane. Manifold size is 3/4" NPT. All controls are tested and confirmed in good working order. Calibration and adjustments are the responsibility of the buyer.

TANK: Easy cleaning, corrosion resistant stainless steel with angled bottom. 3/4" gate valve for rapid draining.

BASKETS: Two heavy duty, nickel plated wire baskets. Permanently affixed hanger rack firmly suspends loaded baskets out of frying vat.

ACCESSORIES: Single large baskets, stainless steel tank covers, gas hoses, cleaning supplies, equipment stands and casters are listed in the price list.

SPECIFICATIONS			
Model		J01HG	2616HG
Width "A"	in.	12	16
	cm	30.5	40.6
Depth "B"	in.	20.5	26.25
	cm	52.1	66.7
Height "C"	in.	22	23.75
	cm	55.9	60.3
Total BTU		18,000	40,000
Approx. Ship	lbs.	60	105
Weight	kgs.	27	48
TANK INTERIOR			
Width	in.	10	13.5
Length	in.	13.5	17.25
Height	in.	6.5	8.25
FRYER TANK FILL CHART GUIDE			
Gallons		2	4
Liters		8	14
Pounds		15	30
Kilograms		7	13.5

[Based on Soybean Oil with a specific gravity of 0.927 at 15°C (59°F).]

This chart is intended to be a guide. Adjustments may be made to accommodate the cooking demands of various establishments.



Comstock-Castle Stove Co. • 119 W. Washington St. • Quincy, IL. 62301
 Tel.: 217-223-5070 • Fax: 217-223-0007 • www.castlestove.com

