



JOB \_\_\_\_\_ ITEM # \_\_\_\_\_

# 30" WIDE RANGES

Base Model: F326, F26



**Model F326**  
(shown with extra rack  
& optional casters)



## Standard Features, Benefits & Options

**CONSTRUCTION:** Easy cleaning, stainless steel finish, sturdily welded with angle iron and corrosion resistant aluminized steel framing. High back splash and shelf is standard. Sturdy 6" stainless steel pipe legs with adjustable feet. Double wall construction with heavy fiberglass insulation assures heat retention for daily money saving fuel efficiency and offers the best installation clearances in the industry. Non-combustible surfaces are 0" on the sides and 0" in the rear, combustible surfaces are 2" on the sides and 2" in the rear. Char-Ranges are to be installed in non-combustible locations only.

**CONTROLS:** 500° thermostat, 100% safety oven shut off, automatic standing pilot and durable brass burner valves. Pressure regulators are set at the factory for the type of gas specified. Optimum pressures are 4" WC for natural gas and 10" WC for propane. Manifold size is 3/4" NPT. All controls are tested and confirmed in good working order. Calibration and installation adjustments are the responsibility of the buyer.

**OVEN:** 26 1/2" wide x 22" deep x 14 1/2" high. One heavy duty chrome plated wire rack is standard with 3 rack positions spaced approximately 2 3/4" apart with 5 3/4" between the top rack position and the ceiling. Easy cleaning porcelain coated and aluminized steel oven linings are standard. The oven features a durable cast iron "H" pattern burner rated at 30,000 BTUH. A special designed baffle directs heat for superior air circulation.

**OPEN BURNERS:** Four 24,000 BTUH "star" pattern burners without gaskets is standard. The large 7" flame spread offers a more efficient burn pattern for small to large pots. Crumb trays catch all spillage. Top grates are 12" x 12" cast iron with a spillover bowl that also reflects heat for added efficiency. A 6" spacer divides the left and right burner sections. Stainless steel bullnose-rail is safely flush with the cook tops and functional to straddle pots, skillets and plates and also serves as control protection.

**GRIDDLES & CHAR-BROILERS:** Only available 18" wide. Griddles feature a 21 1/4" deep grilling surface and 3/4" thickness, 1" thick plates are available Two, "string" burners rated at 18,000 BTUH each for griddles or 20,000 BTUH each for char-broilers. A spatula wide grease trough leads to a front draining, 3 1/2" x 1", grease slot which feeds through a shoot into an easily removable, large capacity, grease drawer. Char-broilers feature heavy, quick heating angle iron radiants to hold temperatures in excess of 700°. 6" wide heavy cast iron char grates feature a cast-in trough in each angled blade to channel grease to the front trough for reduced flare-up and maximum flavor. Each section is reversible for sloping or level cooking. 4" high stainless steel splashguards on 3 sides, higher custom sides are available to meet local fire codes.

**ACCESSORIES & OPTIONS:** Convection fan, extra oven racks, casters, pizza decks, chrome and / or grooved griddle plates, griddle thermostats and / or safety pilot controls, lift off griddles, gas hoses and quick disconnects.



Comstock-Castle Stove Co. • 119 W. Washington St. • Quincy, IL. 62301  
Tel.: 217-223-5070 • Fax: 217-223-0007 • [www.castlestove.com](http://www.castlestove.com)



## 30" WIDE SERIES MEASUREMENTS

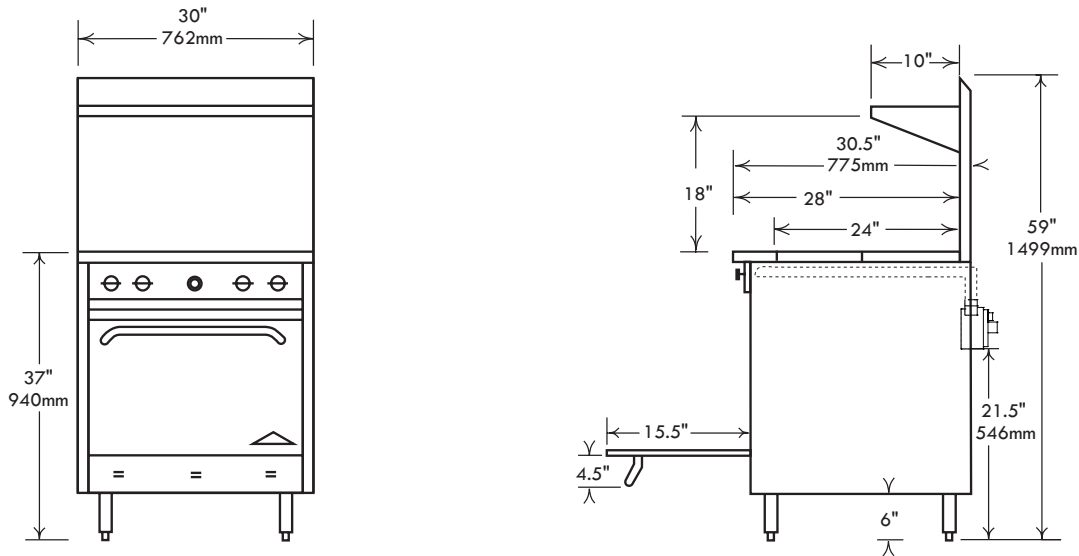

### 30" Restaurant Range Series

Top Configuration	Model #	Description		Total B.T.U.	Approx. Wgt. Kg / Lbs.
		Top	Base		
	F326	(4) Open Burners	- w/ (1) 26.5" Oven	126,000	182 / 400
	F26	(4) Open Burners	- w/ (1) cabinet base	96,000	136 / 300
	F326-18	(2) Open Burners	- w/ (1) 26.5" Oven	114,000	209 / 460
	F26-18	& (1) 18" Griddle	- w/ (1) cabinet base	84,000	164 / 360
	F326-18B	(2) Open Burners	- w/ (1) 26.5" Oven	114,000	223 / 490
	F326-1.5RB	(2) Open Burners	- w/ (1) 26.5" Oven	118,000	195 / 430
	F26-1.5RB	& (1) 18" Radiant Broiler	- w/ (1) cabinet base	88,000	150 / 330
	F326-30	(0) Open Burners	- w/ (1) 26.5" Oven	102,000	239 / 525
	F26-30	& (1) 30" Griddle	- w/ (1) cabinet base	72,000	193 / 425
	F326-30B	(0) Open Burners	- w/ (1) 26.5" Oven	90,000	239 / 525
	F326-2.5RB	(0) Open Burners	- w/ (1) 26.5" Oven	110,000	239 / 525
	F26-2.5RB	& (1) 30" Radiant Broiler	- w/ (1) cabinet base	80,000	193 / 425

Top sections in lieu of open top burners are located on the right when viewing from the front. Special locations may require custom work and pricing, please call the factory for details.

**Approximate Packaging Dimensions:** 34" (711mm) Wide x 37" (940mm) Deep x 37" (940mm) High.

**Gas connection location;** as viewed from the front; 21.5" from the floor, 3" from the left side.

Product improvement is a Comstock-Castle policy and may result in design and specification change without notice.

