

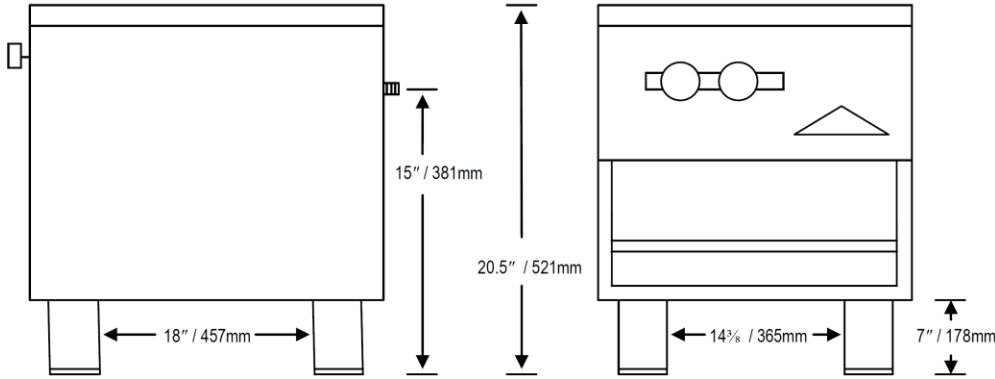

Est.1838 • Commercial Cooking Equipment

# STOCK POT STOVE

## SRSP Series



Model  
SRSP18-1 / TH-RB-1



## Standard Features, Benefits & Options

**CONSTRUCTION:** Heavy gauge welded and bolted frame for rugged usage. Standard finish is easy cleaning stainless steel on all exterior surfaces. 7" heavy duty stainless steel legs with adjustable feet up too an additional 2".

**CONTROLS:** Castle stock pot stoves are equipped with brass gas valves, automatic standing pilots, pressure regulators and cool to the touch control knobs.

**BURNERS:** SRSP models feature long life double venturi, cast iron burners rated up to a total of 87,000 BTUs.

**TOP GRATES:** Heavy duty one piece cast iron with cast in bull nose. designed to accommodate pots as large as 14"-24" in diameter.

**TESTING:** The gas system is tested before shipment. Optimal pressure is 4" WC for natural gas, 10" WC for propane.

**ACCESSORIES & OPTIONS:** Gas hoses, wok rings, set screw knobs and casters.

Model Number	Width x Depth		Burner Sections	Total BTU	Ship Weight	
	in	mm			lbs.	kgs.
SRSP18 ----- TH-RB-1	18 x 21	457 x 530	1	82,000	105	47.7
SR2SP18 ----- TH-RB-2A	18 x 42	457 x 1066	2	164,000	220	100
SR4SP36 * ----- TH-RB-4A *	36 x 42	914 x 1066	4	328,000	460	209

\* not ETL design listed



Comstock-Castle Stove Co. • 119 W. Washington St. • Quincy, IL. 62301  
Tel.: 217-223-5070 • Fax.: 217-223-0007 • Web: www.castlestove.com

