

## COOK-N-HOLD LOW TEMPERATURE RADIANT OVEN MODEL 1000-CH-SS-SPLIT SERIES

### FEATURES AND BENEFITS:

- Fully insulated Cook-N-Hold gentle radiant oven designed for flavorful results by slow cooking.
- Slow cooking means 15% to 20% less shrinkage.
- Efficient 3000 Watt power unit allows for reheating of prepared meals or bulk items. Maximum temperature 325° (163°C). Easy to read thermometer.
- Pre-setting automatic controls for cooking and holding cycles allows for unattended operation.
- Cook and hold over 120 lbs. (54 kg.) of meat in just 5 sq. ft. of floor space.
- Non-venting oven, permitted by most local codes, provides easy, inexpensive installation.
- Fully insulated, stainless steel interior and exterior for ease of cleaning.
- Oven is operable on either 208 or 240 Volt circuits at the flip of a switch.
- Smooth interior coved corners prevent food particle/grease buildup.
- Field reversible insulated door prevents temperature loss. Silicone door gasket for proper seal. High temperature ceramic magnetic latch for "easy open" and security during transport.
- Safety conscious anti-microbial latch protect against spreading germs.
- Standard with right hand hinges; left hand hinging available upon request.
- Stainless steel pan slides hold eight (8) 18" x 26" pans on 3" centers. Supplied with 3 wire grids.
- Heavy duty 5" swivel casters, two with brakes. Provides mobility when fully loaded.
- Ovens can be stacked for flexibility.

### POWER UNIT OPTIONS:

3000 Watts, 208/240 Volts, 1 Phase, 60 Hz.

3000 Watts, 208/240 Volts, 3 Phase, 60 Hz.



**7 Year Limited Warranty**  
On all Cook-N-Hold heating elements (Excludes Labor).



5925 Heisley Road • Mentor, OH 44060-1833  
Phone: 877/CRESCOR • Fax: 440/350-7267  
www.crescor.com



1000-CH-SS-SPLIT



**SANITATION**  
NSF/ANSI 4



**C US**

### ACCESSORIES and OPTIONS (Available at extra cost):

- Tempered Glass Door Window
- Key Lock Latch
- Extra Wire Grids
- Perimeter Bumper
- Corner Bumpers
- Floor Lock (for use with 5" casters)
- Various Caster Options
- Cord Installation

See page E-10 for accessory details.

# 1000-CH-SS-SPLIT SERIES

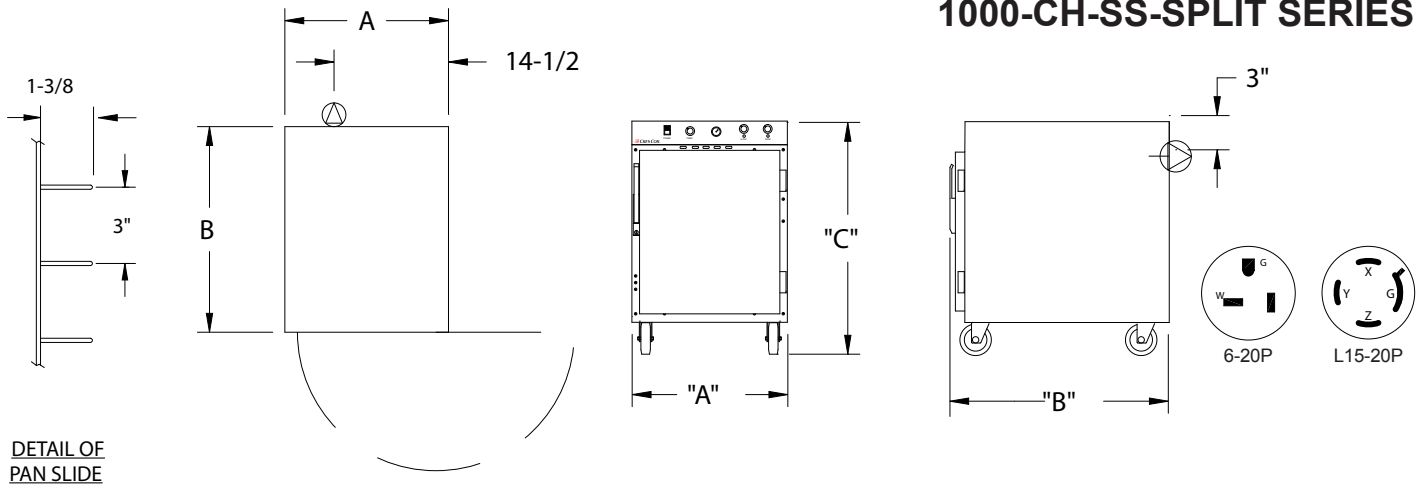

DETAIL OF PAN SLIDE

CRES COR MODEL NO.	PAN			DIM "A"	DIM "B"	DIM "C"	INSIDE DIMENSIONS*				WEIGHT ACT.
	CAP	SIZE		WIDTH	DEPTH	HEIGHT	WIDTH	DEPTH	HEIGHT		
1000-CH-SS-SPLIT	8	18 X 26	IN	22-5/8	32-3/4	42	18-3/16	27	26-3/4	LBS	215
		460 X 660	MM	575	835	1070	465	690	680	KG	98
1000-CH-SS-SPLIT (Stacked)	16	18 X 26	IN	22-5/8	32-3/4	77	18-3/16	27	26-3/4	LBS	430
		460 X 660	MM	575	835	1960	465	690	680	KG	195

\*Inside dimensions for each compartment

## CABINET:

- Body: 22 ga. stainless steel outer body.
- Inner body & top: 18 ga. stainless steel.
- Reinforcement: Internal framework of 18 ga. stainless steel.
- Insulation: Fiberglass, thermal conductivity (K factor) is .23 at 75°F, 1-1/2" in walls, 1" in doors.
- Drip pan: 18 ga. stainless steel with drain.
- Casters: 5" dia., swivel, modulus tires, 1-1/4 wide, load cap. 250 lbs. each, temp. range -45°/+180°F. Delrin bearings. Front casters equipped with brakes.

## DOOR:

- Field reversible.
- Formed 20 ga. stainless steel.
- Latch: Anti-microbial chrome plated zinc with composite handle, ceramic magnetic type; mounted inboard.
- Hinges (2): Heavy duty chrome plated zinc; mounted inboard
- Gaskets: Perimeter type, silicone.

## PAN SLIDES:

- 18 ga. stainless steel angles, 1 x 1-3/8; riveted on 3" centers.
- Grids: Stainless steel, 18 x 26; supplied with (3) grids.

## CLEARANCE REQUIREMENTS:

- 3" (76mm) at the back, 2" (51mm) at the top, 1" (25mm) at both sides.

## POWER REQUIREMENTS:

- 3000 Watts, 208/240 Volts, 60 Hz., 1 phase, 20 Amp. Service 14 Amps at 208 Volts, 13 Amps at 240 Volts.
- 3000 Watts, 208/240 Volts, 60 Hz., 3 phase, 20 Amp. Service 8 Amps at 208 Volts, 7 Amps at 240 Volts.

## ELECTRICAL COMPARTMENT:

- Control panel: Formed stainless steel; black front.
- Thermostat (HOLD): Electro-mechanical, 140°F (60°C) to 200°F. (93°C.).
- Thermostat (COOK): Electro-mechanical, 140°F (60°C) to 325°F. (163°C).
- Switch: Lighted ON-OFF rocker type.
- Timer: 18 hr.
- Pilot lights.
- Power Cord: Permanent, 6 ft. 12/3 ga. with right angle plug.
- Three (3) heater circuits.
- Thermometer.
- Voltage selector switch: Change to 208 or 240 Volt; on back of oven.

## INSTALLATION REQUIREMENTS:

- Check local vent hood codes for mobile Cook-N-Hold ovens.
- Ovens with no cord or plug must be attached to building with a flexible connector. Not factory supplied.

## SHORT FORM SPECIFICATIONS

Cres Cor Insulated Radiant Oven Model 1000-CH-SS-SPLIT; Outer body of 22 ga. stainless steel; inner body, top and frame of 18 ga. stainless steel. Fiberglass insulation 1-1/2" in walls; 1" in door. Stainless steel internal frame; coved corners. Anti-microbial chrome plated latch. Thermometer. Three (3) heated inner walls. Removable pan supports for (8) 18" x 26" pans spaced on 3" centers. Casters 5" swivel modulus casters, Delrin bearings. Load capacity 250 lbs. each. 2-Year Parts / 1-Year Labor warranty. Lifetime on heating elements (excluding labor). Provide the following accessories: \_\_\_\_\_ CSA Sanitation and safety certified US & CAN.



5925 Heisley Road • Mentor, OH 44060-1833  
Phone: 877/CRESCOR • Fax: 440/350-7267  
www.crescor.com

© Crescent Metal Products, Inc. 2011 All rights reserved.

*In line with its policy to continually improve its products, CRES COR reserves the right to change materials and specifications without notice.*

Litho in U.S.A.