

NON-INSULATED TRAY DELIVERY CART MODEL 101-1418 SERIES

FEATURES AND BENEFITS:

- Non-insulated cabinet for tray transport and storage. Ideal for use as a patient tray delivery cart.
- Same size top and base extend past sidewalls to act as natural bumpers for protection. Extruded frame fully welded.
- Body constructed of non-corrosive, Hi-Tensile aluminum for strength and ease of mobility
- Pass-thru design available for easy access from either side. Model 101P-1418-20.
- Reinforced, full length door swings 270° and can be latched to the cabinet side for convenience. Card clip included.
- Gravity type latch secures door during transport.
- Extruded angle ledge pan supports hold 14" x 18" trays on 5-1/2" centers.
- Interior pan stop on door allow proper air flow.
- Heavy duty 5" swivel casters, two with brakes. Provides mobility when fully loaded.



101-1418-10



ACCESSORIES and OPTIONS (Available at extra cost):

- Pass-Thru
- Lock Hasp
- Various Caster Options
- Corner Bumpers
- Perimeter Bumper
- Floor Lock (for use with 5" casters)
- Plexiglass Door
- Push Handle
- Bail Handle Kit
- Left-Hand Hinged Door
- Kold Keepers

See page A-20 for accessory details.

101-1418 Series

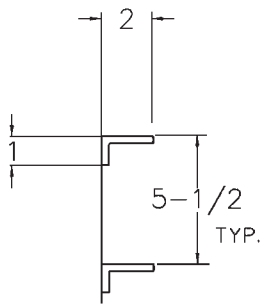

DETAIL OF
PAN SLIDE

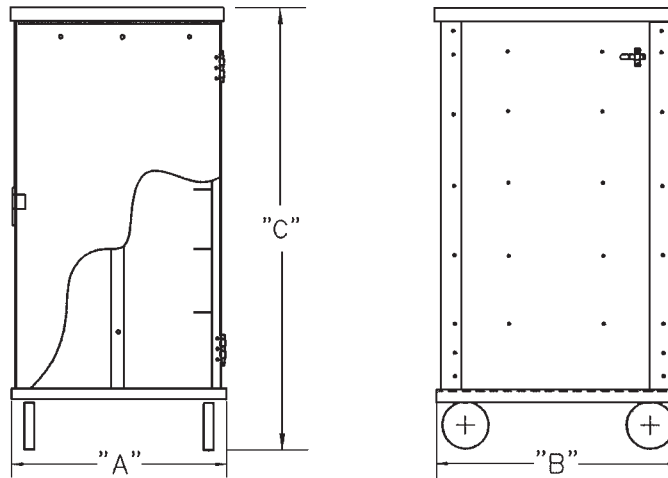

CRES COR MODEL NO.	PAN			DIM "A"	DIM "B"	DIM "C"	INSIDE DIMENSIONS			WEIGHT ACT.	
	CAP	SIZE		WIDTH	DEPTH	HEIGHT	WIDTH	DEPTH	HEIGHT		
101-1418-10	10	14 x 18	IN	21	31	35-3/4	18-3/16	28-1/2	27-1/2	LBS	96
		360 x 460	MM	535	790	910	465	725	700	KG	44
101-1418-20*	20	14 x 18	IN	21-3/4	31-1/2	63-3/4	18-15/16	29	55-1/2	LBS	126
		360 x 460	MM	555	800	1620	480	740	1410	KG	57

When ordering bumpers, add 2" to overall dimensions.

*Pass-Thru available model 101P-1418-20.

ALL CONSTRUCTION IS RIVETED, WELDED AND FINISHED.

CABINET:

- Top: One piece .063 aluminum.
- Posts: Extruded aluminum channels, 7/8 x 2-1/4 x .102, welded to top and base, form a solid frame.
- Sides: .063 panels riveted to posts.
- Tie rod: Applied at front and back.
- Pan stop channels: Riveted to inside rear of cabinet and door.

BASE:

- One piece construction, .125 aluminum.
- Casters: 5" dia., modulus tires, 1-1/4" wide, load cap. 250 lbs. each, temp. range -40°/+180°F. Delrin bearings. Front casters equipped with brakes.

DOORS:

- Panels: Formed .063 aluminum.
- Reinforcements: 3/8 x 1-1/2 extruded bars riveted and welded horizontally to top, center and bottom.
- Latches: Gravity type, nickel plated steel.
- Swings 270° on butt hinges, riveted to posts and door panels.
- Slide latch holds door open.

PAN SLIDES:

- Angles: Extruded angle supports 1 x 2 x .125 riveted to sides on 5-1/2" centers.

SHORT FORM SPECIFICATIONS

Cres Cor Utility Cabinet Model 101-1418-____. Formed and welded .063 aluminum top, .125 aluminum base. Extruded aluminum angles riveted on 5-1/2" centers. Holds (____) 14" x 18" trays. Formed .063 aluminum door(s). 5" modulus casters, front casters with brakes. Load capacity 250 lbs. each, temperature -40° to +180° F. Provide the following accessories: _____ . NSF listed. 2 year parts warranty.



5925 Heisley Road • Mentor, OH 44060-1833
Phone: 877/CRES COR • Fax: 440/350-7267
www.crescor.com

© Crescent Metal Products, Inc. 2010 All rights reserved.

In line with its policy to continually improve its products, CRES COR reserves the right to change materials and specifications without notice.

Litho in U.S.A.