

TRANSPORT DOLLY 500-026

FEATURES AND BENEFITS:

- Heavy duty dolly for storage and transport of baskets.
- Constructed of non-corrosive, Hi-Tensile aluminum.
- Base formed of .190 aluminum for strength and durability. Reinforced with 3/16" thick extruded angles.
- Heavy duty 5" swivel casters, two with brakes. Provides mobility when fully loaded. No rust sealed bearings prevent "wheel lock" in wet environments. Zerk fittings in axles and dust caps.



500-026



ACCESSORIES and OPTIONS (Available at extra cost):

- Corner Bumpers

See page H-9 for accessory details.

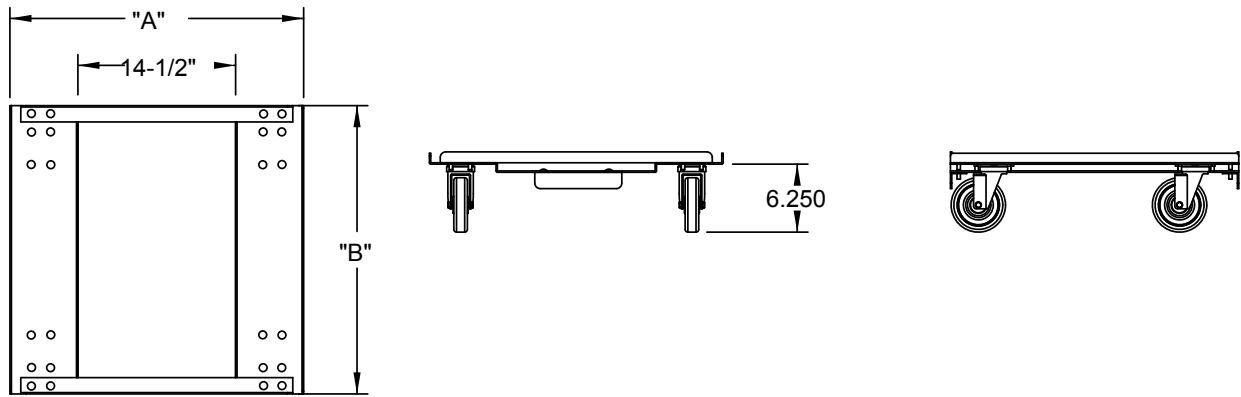

CRES COR MODEL NO.		DIM "A"	DIM "B"	DIM "C"	INSIDE DIMENSIONS			WEIGHT ACT.
		WIDTH	DEPTH	HEIGHT	WIDTH	DEPTH		
500-026	IN	27	26-1/2	7-3/8	26-5/8	26-1/8	LBS	38
	MM	685	675	190	680	665	KG	18

BASE:

- Formed .190 aluminum.

ANGLES:

- Top side: (2) Extruded 1" x 1-1/2" x 3/16" thick aluminum
- Underneath: (2) Extruded 1-1/2" x 1-1/2" x 3/16" thick aluminum.

CASTERS:

- Four (4) 5" dia. swivel casters, Advantage tires, 1-1/4" wide, load capacity 250 lbs. each wheel; temp range: -45°/+180°F. Sealed, lubricated Delrin bearings; (2) casters with brakes. Zerk fittings in axles and dust caps.
- Casters and angles fastened to dolly base with carriage bolts, 5/16" x 3/4", lock washers and hex nuts.

SHORT FORM SPECIFICATIONS

Cres Cor Transport Dolly Model 500-026 formed of .190 aluminum, extruded angles fastened with carriage bolts. Five inch swivel modulus casters have Delrin bearings. Zerk fittings. Load capacity 250 lbs. each wheel. Provide the following accessories: _____ .
1-Year Parts & Labor warranty.



5925 Heisley Road • Mentor, OH 44060-1833
Phone: 877/CRESCOR • Fax: 440/350-7267
www.crescor.com

© Crescent Metal Products, Inc. 2014 All rights reserved.

In line with its policy to continually improve its products, CRES COR reserves the right to change materials and specifications without notice.

Litho in U.S.A.