

COOK-N-HOLD LOW TEMPERATURE SMOKER OVEN MODEL 767-CH-SK-D

FEATURES AND BENEFITS:

- Fully insulated Cook-N-Hold smoker designed for flavorful results by slow cooking. Slow cooking means 15% to 20% less shrinkage. More product yield.
- Smokes with real wood chips. Cold smoke fish and cheese as well with Kold Keepers.
- Efficient 3000 Watt power unit allows for reheating of prepared meals or bulk items. Maximum temperature 325° (163°C). Powerful 250 Watt cal rod heats chips quickly.
- Includes stainless steel vented chip box and variable one hour timer for mild to heavy smoke flavor.
- Standard solid state electronic control with large, clean, easy-to-read and operate LED digital display to ensure holding at precise food temperatures.
- 18 factory or field programmed cook & hold cycles. Each programmed menu can be customized for exact time and temperature needs.
- Standard with probe cooking, includes one 6" food temperature probe.
- Cook and hold up to 100 lbs. (45 kg.) of meat in less than 6 sq. ft. of floor space.
- Fully insulated, stainless steel interior and exterior for ease of cleaning. Smooth interior coved corners prevent food particle/grease buildup.
- Oven is operable on either 208 or 240 Volt circuits at the flip of a switch.
- Field reversible insulated door prevents temperature loss. Silicone door gasket for proper seal. High temperature ceramic magnetic latch for "easy open" and security during transport.
- Safety conscious anti-microbial latch protect against spreading germs. Standard with right hand hinges; left hand hinging available upon request.
- Removable stainless steel pan slides have eleven positions on 1-3/8" centers. Supplied with 3 stainless steel wire grids.
- External drip pan on front keeps traffic area dry, safer.
- Heavy duty 3½" casters, two swivel with brakes; two rigid. Provides mobility when fully loaded.
- Ovens can be stacked for flexibility and increased capacity.
- Cres Cor recommends soaking wood chips for a minimum of 24 hours before usage.

POWER UNIT OPTIONS:

3000 Watts, 208/240 Volts, 1 Phase, 60 Hz.

3000 Watts, 208/240 Volts, 3 Phase, 60 Hz.



767-CH-SK-D



ACCESSORIES and OPTIONS (Available at extra cost):

- Kold Keeper
- Stacking Kit
- Tempered Glass Door Window
- Key Lock Latch
- Extra Wire Grids
- Perimeter Bumper
- Corner Bumpers
- Various Caster Options
- 120 Volt Service
- Mobile Equipment Stand 24"

See page E-10 for accessory details.

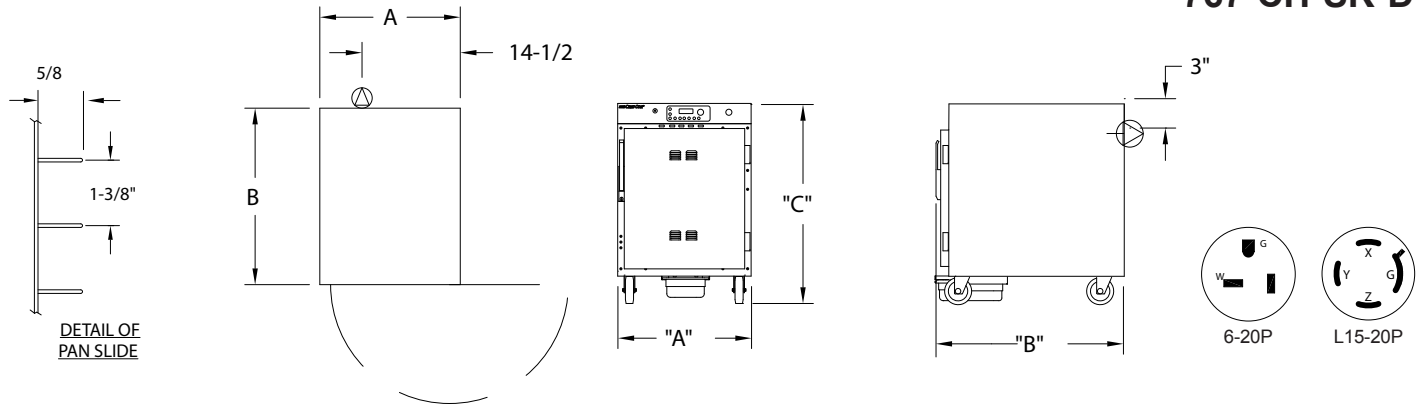

CRES COR MODEL NO.	PAN			DIM "A" WIDTH	DIM "B" DEPTH	DIM "C" HEIGHT	INSIDE DIMENSIONS			WEIGHT ACT.	
	CAP	SIZE					WIDTH	DEPTH	HEIGHT		
767-CH-SK-D	9	12 X 20 X 2-1/2	IN	25-5/8	32-3/4	32-1/4	21-3/16	27	17-1/2	LBS	205
		305 X 510 X 65	MM	655	835	820	540	690	444	KG	113
	6	12 x 20 x 4	IN								
		305 x 510 x 105	MM								
	4	12 x 20 x 6	IN								
		305 x 510 x 155	MM								
	5*	18 x 26 x 1	IN								
		460 x 660 x 255	MM								

*Additional shelves required.

CABINET:

- Body: 22 ga. stainless steel outer body.
- Inner body & top: 18 ga. stainless steel.
- Reinforcement: Internal framework of 18 ga. stainless steel.
- Insulation: Fiberglass, thermal conductivity (K factor) is .23 at 75°F, 1-1/2" in walls, 1" in doors.
- Drip pan: 18 ga. stainless steel with drain; removable.
- Wood chip box (removable): 18 ga. stainless steel; 3-5/8" L x 8" W x 2-1/4" H with 8" long handle; mounts on lower rear wall.
- Casters: 3-1/2" dia., modulus tires, 1-1/4" wide, load cap. 225 lbs. each, temp. range -45°/+180°F. Delrin bearings. Front swivel casters equipped with brakes; rigid casters on rear.

DOOR:

- Field reversible.
- Formed 20 ga. stainless steel.
- Latch: Anti-microbial chrome plated zinc with composite handle, ceramic magnetic type; mounted inboard.
- Hinges (2): Heavy duty chrome plated zinc; mounted inboard
- Gaskets: Perimeter type, silicone.
- Adjustable vents.

PAN SLIDES (removable):

- 18 ga. stainless steel angles, 5/8 x 1; riveted on 1-3/8" centers.
- Grids: Stainless steel, 21 x 26; supplied with (3) grids.

CLEARANCE REQUIREMENTS:

- 3" (76mm) at the back, 2" (51mm) at the top, 1" (25mm) at both sides.

POWER REQUIREMENTS:

- 3000/2650 Watts, 208/240 Volts, 60 Hz., 1 phase, 20 Amp. Service 14 Amps at 208 Volts, 13 Amps at 240 Volts.
- 3000/2650 Watts, 208/240 Volts, 60 Hz., 3 phase, 20 Amp. Service 8 Amps at 208 Volts, 7 Amps at 240 Volts.

ELECTRICAL COMPARTMENT:

- Control panel: Formed stainless steel; black front.
- Thermostat (cook/hold): Solid state digital display control, 140°F (60°C) to 325°F (163°C).
- Switch: ON-OFF push button type.
- Power Cord: Permanent, 6 ft. with right angle plug.
- Probe: (1) 6", stainless steel.
- Three (3) heater circuits.
- One hour smoker timer with power light.
- Thermometer: Digital display.
- Voltage selector switch: Change to 208 or 240 Volt; on back of oven.

INSTALLATION REQUIREMENTS:

- Check local vent hood codes for mobile Cook-N-Hold ovens.

SHORT FORM SPECIFICATIONS

Cres Cor Insulated Under Counter Smoker Oven Model 767-CH-SK-D; Solid state electronic controlled times and temperatures. Outer body of 22 ga. stainless steel; inner body and frame of 18 ga. stainless steel. Fiberglass insulation 1-1/2" in walls; 1" in door. Stainless steel internal frame; coved corners. Anti-microbial chrome plated latch. Three (3) heated inner walls. Smoker box and timer. Removable pan supports for (9) 12" x 20" x 2-1/2" pans spaced on 2-3/4" centers. Casters 3-1/2" modulus casters (2) swivel, (2) rigid, Delrin bearings. Load capacity 225 lbs. each. 2-Year Parts / 1-Year Labor warranty. Lifetime on heating elements (excluding labor). Provide the following accessories: _____ . CSA Sanitation and safety certified US & CAN.



5925 Heisley Road • Mentor, OH 44060-1833
 Phone: 877/CRESCOR • Fax: 440/350-7267
 www.crescor.com

© Crescent Metal Products, Inc. 2014 All rights reserved.

In line with its policy to continually improve its products, CRES COR reserves the right to change materials and specifications without notice.

Litho in U.S.A.