

INSULATED HEATED STAINLESS STEEL BANQUET CART MODEL CCB-120A

FEATURES AND BENEFITS:

- Fully insulated banquet cart designed to hold plated covered meals.
- Self contained power top lifts off for easy cleaning.
- Easy-to-read eye level controls.
- Standard 1650 Watts, 120 Volts, 15 Amps Provides quick heat up to 200°F (93°C).
- Use for short term cold food storage. Factory installed slides hold 2 accessory Kold Keepers.
- Stainless steel construction throughout for ease of cleaning.
- Two inch thick insulation for energy efficiency.
- Supplied with six wire grid shelves; easily removed yet secure.
- Fully insulated doors swing flush to sides; latch in place for ease of loading and unloading.
- Recessed push/pull handles on both sides prevent damage to walls; allows easy maneuvering.
- One piece welded base with perimeter bumper provides solid foundation to support heavy loads.
- Heavy duty 6" modulus wheels, two swivel with brakes. Rolls easily, even over carpeted surfaces. Staggered mounting provides mobility when fully loaded especially over uneven surfaces.



CCB-120A



ACCESSORIES and OPTIONS (Available at extra cost):

- Gravity Transport Latch
- Menu Card Holder
- Digital Thermometer
- Thermometer Cover
- Kold Keepers
- Various Caster Options
- 240 Volt Service

See page F-4 for accessory details.

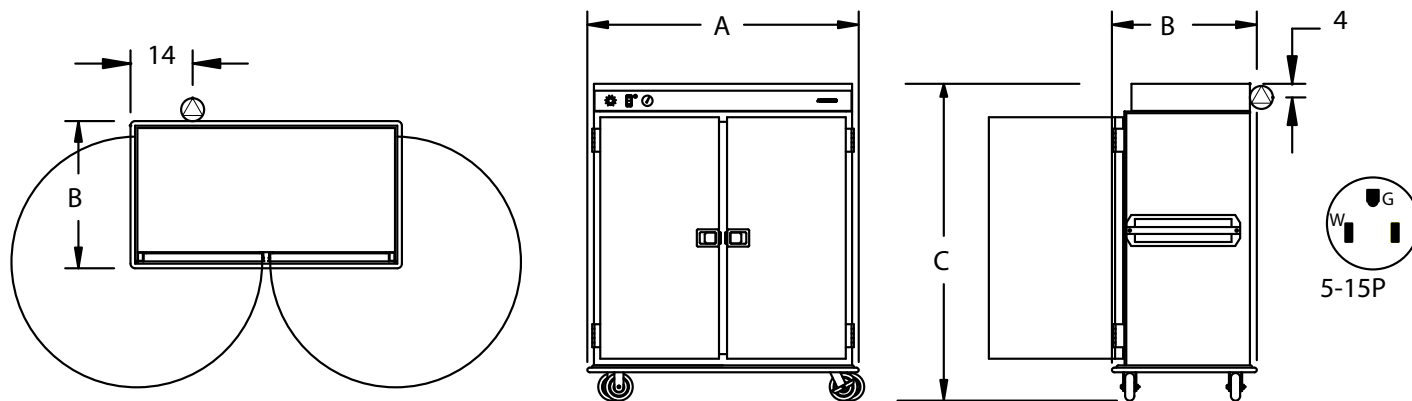

CRES COR MODEL NO.	MEAL CAPACITY COVERED PLATE DIA.				DIM "A"	DIM "B"	DIM "C"	INSIDE DIMENSIONS*			WEIGHT ACT.	
	11"	11-3/4"	13"		WIDTH	DEPTH	HEIGHT	WIDTH	DEPTH	HEIGHT		
CCB-120A	120	90	60	IN	59	32-3/8	68-7/8	22	23	50-1/2	LBS	530
				MM	1500	825	1745	560	585	1285	KG	240

*Dimensions for each side.

Capacity based on covered plate dia. with nesting height of 3" for plate and cover.

ALL CONSTRUCTION IS RIVETED, WELDED AND FINISHED.

CABINET:

- Body: 22 ga. non-magnetic stainless steel.
- Inner Liner: 22 ga. 300 series stainless steel.
- Reinforcement: Internal framework of 14 ga. 300 series stainless steel.
- Insulation (walls, doors, base): 2" fiberglass, thermal conductivity (K factor) is .23 at 75°F.
- Push handles: 1" dia. stainless steel tubing, recessed on both sides.
- Rack insert posts: Removable 18 ga. 300 series stainless steel channels.

BASE:

- One piece construction, .190 aluminum, welded.
- Casters: 6" dia., modulus tires, 2" wide, load cap. 450 lbs. each, temp. range -45°/+180°F. Zerk fittings in hub. Two rigid type. Two swivel type equipped with brakes.
- Perimeter bumper: Gray, non-marking rubber, 1 x 1.

DOORS:

- Formed 22 ga. non-magnetic stainless steel.
- Latches: Polished stainless steel, slam type; mounted inboard.
- Door gaskets: Perimeter type, silicone.
- Pan stop channels: 22 ga. 300 series stainless steel attached to inner doors.
- Swings 270° on two heavy duty butt hinges; held open on friction catches.

PAN SLIDES:

- Angles: Formed 16 ga. 304 stainless steel.
- Three sets of 1 x 1 angles on each side.
- Shelves: Six nickel chrome plated wire grids, 21-1/2 x 22-1/2.
- Shelf clearance: 16" between shelves; adjustable on 1-1/2" centers.

HOT UNIT COMPONENTS:

- Body: Formed of 20 ga. non-magnetic stainless steel with black powder coated control panel.
- Removable without tools.
- Thermostat: Electro-mechanical, ambient to 200°F (93°C).
- Switch: ON-OFF rocker type.
- Thermometer.
- Power cord: Permanent, 10 ft., 14/3 ga. with molded plug.
- Heaters (2): 750 Watts each.
- Blower motors (2).
- Slides for Kold Keeper (2 cap.).
- Metal strain relief.

POWER REQUIREMENTS:

- 1650 Watts, 120 Volts, 60 Hz., single phase, 13.8 Amps., 15 Amp. service.

SHORT FORM SPECIFICATIONS

Cres Cor Heated Banquet Cart Model CCB-120A. Cabinet 22 ga. non-magnetic stainless steel. Doors and body 2" fiberglass insulation. Eye level controls on removable top. Doors swing 270°; held open on friction catches. Recessed side push handles. Six nickel chrome plated wire grids. Capacity 120 covered meals. Base one piece .190 aluminum, welded and finished, perimeter bumper. Six inch modulus casters. Load capacity 450 lbs. each. 1650 Watts, 120 Volts, 60 Hz., 1 Phase, 15 Amp. service. 2-Year Parts / 1-Year Labor warranty. Provide the following accessories: _____ CSA-US, CSA-C, CSA to NSF4 listed. ENERGY STAR Qualified.



5925 Heisley Road • Mentor, OH 44060-1833
 Phone: 877/CRESCOR • Fax: 440/350-7267
 www.crescor.com

© Crescent Metal Products, Inc. 2011 All rights reserved.

In line with its policy to continually improve its products, CRES COR reserves the right to change materials and specifications without notice.

Litho in U.S.A.