

ROAST-N-HOLD™ GENTLE CONVECTION OVEN MODEL CO-151-F-1818D

FEATURES AND BENEFITS:

- Fully insulated Roast-N-Hold gentle convection oven designed for flavorful results by slow roasting.
- Slow convected air system promotes natural browning for flavor and seals in natural juices. Slow roasting means 15% to 20% less shrinkage.
- Full 8200 Watts of power allows for rethermalizing of prepared meals or bulk items. Maximum temperature 350°F. (176.5°C.).
- Standard solid state electronic control with large, clean, easy-to-read and operate LED digital display to ensure holding at precise food temperatures.
- 18 factory or field programmed roast & hold cycles. Each programmed menu can be customized for exact time and temperature needs.
- Standard with probe cooking, includes one 6" food temperature probe.
- Roast and hold over 300 lbs. (136 kg.) of meat in just 7 sq. ft. of floor space.
- Non-venting oven, permitted by most local codes, provides easy, inexpensive installation.
- Stainless steel construction throughout for ease of cleaning.
- Smooth interior coved corners prevent food particle/grease buildup.
- Field reversible insulated Dutch doors prevent temperature loss. Silicone door gaskets for proper seal. High temperature ceramic magnetic latches for "easy open" and security during transport.
- Safety conscious anti-microbial latches protect against spreading germs. Standard with right hand hinging; left hand hinging available upon request.
- Channel pan slides securely hold 18" x 26" pans on 3" centers without tipping. Provides added strength. Supplied with six raised wire grids.
- Heavy duty 5" swivel casters, two with brakes. Provides mobility when fully loaded.

POWER UNIT OPTIONS:

8200 Watts, 208 Volts, 1 Phase, 60 Hz.
8200 Watts, 240 Volts, 1 Phase, 60 Hz.
8200 Watts, 208 Volts, 3 Phase, 60 Hz.
8200 Watts, 240 Volts, 3 Phase, 60 Hz.



CO-151-F-1818D



NSF/ANSI 4



C US



New, easier to use, easy-to-read and operate LED digital display ensures holding at precise food temperatures and moisture content.

ACCESSORIES and OPTIONS (Available at extra cost):

- Security Panel for Controls
- Tempered Glass Door Windows
- Key Lock Latches
- 1-1/2" Food Temperature Probe
- Extra Wire Grids
- Perimeter Bumper
- Corner Bumpers
- Rear Push Handle
- 6" Dia. Casters
- Polyurethane Casters
- HACCP Documentation (built in USB port)

See page E-10 for accessory details.

CO-151-F-1818D

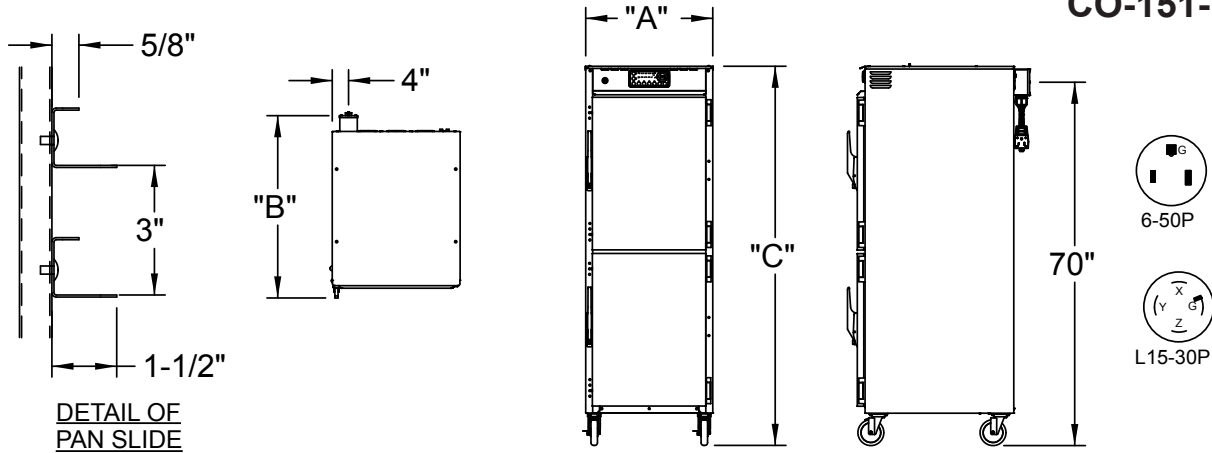

CRES COR MODEL NO.	PAN			DIM "A"	DIM "B"	DIM "C"	INSIDE DIMENSIONS				WEIGHT ACT.
	CAP	SIZE		WIDTH	DEPTH	HEIGHT	WIDTH	DEPTH	HEIGHT		
CO-151-F-1818D	18	18 X 26	IN	25-3/8	37-3/4	73-1/2	18-1/4	26-1/2	58	LBS	415
		460 X 660	MM	645	960	1870	465	675	1475	KG	188

When ordering bumpers, add 2" to overall dimensions.

CABINET:

- Body: 22 ga. stainless steel.
- Reinforcement: Internal framework of 16 ga. stainless steel.
- Insulation: Fiberglass, thermal conductivity (K factor) is .23 at 75°F. 1-1/2" in back wall, doors, base; 2" in side walls.
- Air tunnels: 20 ga. stainless steel, lift-out type, mounted on sides.
- Interior coved corners.

BASE:

- One piece construction, .125 aluminum.
- Casters: 5" dia., swivel, modulus tires, 1-1/4 wide, load cap. 250 lbs. each, temp. range -45°/+180°F. Delrin bearings. Front casters equipped with brakes.

DUTCH DOORS:

- Field reversible.
- Formed 22 ga. stainless steel.
- Latches: Chrome plated zinc with composite handle, ceramic magnetic type.
- Hinges: Heavy duty chrome plated zinc.
- Gaskets: Perimeter type, silicone.
- Pan stops: Embossed.

PAN SLIDES:

- 18 ga. stainless steel channels riveted on 3" centers.
- Grids (6): Nickel chrome plated steel, raised wire 17" x 25".

POWER REQUIREMENTS AVAILABLE:

- 8200 Watts, 208 Volts, 60 Hz., 1 phase, 39 Amps., 50 Amp. service.
- 8200 Watts, 240 Volts, 60 Hz., 1 phase, 34 Amps., 50 Amp. service.
- 8200 Watts, 208 Volts, 60 Hz., 3 phase, 23 Amps., 30 Amp. service.
- 8200 Watts, 240 Volts, 60 Hz., 3 phase, 20 Amps., 30 Amp. service

ELECTRICAL COMPONENTS:

- Thermostat (roast/hold): Solid state digital control, 140°F to 350°F (176.5°C).
- Switch: ON-OFF push button type.
- Thermometer: Digital.
- Power cord: Permanent, 8 ft., 6 ga. with right angle plug.
- Heaters (6): 1325 Watts each.
- Blower motors (4).
- Vent fans (3).
- Fuses (2): 6 Amp.
- Probe (1): 6" stainless steel.

INSTALLATION REQUIREMENTS:

- Check local vent hood codes for mobile Roast-N-Hold ovens.

SHORT FORM SPECIFICATIONS

Cres Cor Roast-N-Hold Convection Oven Model CO-151-F-1818D. 18 ga. stainless steel, recessed control panel with digital thermostat. Cabinet and Dutch doors 22 ga. stainless steel; stainless steel internal frame; coved corner interior. Fiberglass insulation in sides 2"; back, doors and base 1-1/2". High temperature anti-microbial magnetic latches. No-tip channel interior for 18" x 26" pans on 3" centers. One piece base .125 aluminum. 5" swivel modulus casters, Delrin bearings. Load capacity 250 lbs. each. 8200 Watts, _____ Volts, 60 Hz., _____ Phase. 2-Year Parts / 1-Year Labor warranty. Provide the following accessories: _____ CSA-US, CSA-C, CSA to NSF4 listed.



5925 Heisley Road • Mentor, OH 44060-1833
 Phone: 877/CRESCOR • Fax: 440/350-7267
 www.crescor.com

© Crescent Metal Products, Inc. 2014 All rights reserved.

In line with its policy to continually improve its products, CRES COR reserves the right to change materials and specifications without notice.

Litho in U.S.A.