

## ROAST-N-HOLD™ GENTLE CONVECTION OVEN MODEL CO-151-H-189D (HALF SIZE)

### FEATURES AND BENEFITS:

- Fully insulated half size Roast-N-Hold gentle convection oven designed for flavorful results by slow roasting.
- Slow convected air system promotes natural browning for flavor and seals in natural juices. Slow roasting means 15% to 20% less shrinkage.
- Efficient 4700 Watt power unit allows for reheating of prepared meals or bulk items. Maximum temperature 350°F. (176.5°C.).
- Standard solid state electronic control with large, clean, easy-to-read and operate LED digital display to ensure holding at precise food temperatures.
- 18 factory or field programmed roast & hold cycles. Each programmed menu can be customized for exact time and temperature needs.
- Standard with probe cooking, includes one 6" food temperature probe.
- Roast and hold over 120 lbs. (54 kg.) of meat in just 6 sq. ft. of floor space.
- Non-venting oven, permitted by most local codes, provides easy, inexpensive installation.
- Stainless steel construction throughout for ease of cleaning.
- Smooth interior coved corners prevent food particle/grease buildup.
- Field reversible insulated door prevents temperature loss. Silicone door gasket for proper seal. High temperature ceramic magnetic latch for "easy open" and security during transport.
- Safety conscious anti-microbial latch protects against spreading germs. Standard with right hand hinging; left hand hinging available upon request.
- Channel pan slides securely hold 18" x 26" pans on 3" centers without tipping. Provides added strength. Supplied with three raised wire grids.
- Heavy duty 5" swivel casters, two with brakes. Provides mobility when fully loaded.
- Ovens can be stacked for flexibility.

### POWER UNIT OPTIONS:

4700 Watts, 208 Volts, 1 Phase, 60 Hz.  
 4700 Watts, 240 Volts, 1 Phase, 60 Hz.  
 4700 Watts, 208 Volts, 3 Phase, 60 Hz.  
 4700 Watts, 240 Volts, 3 Phase, 60 Hz.



CO-151-H-189D



New, easier to use, easy-to-read and operate LED digital display ensures holding at precise food temperatures and moisture content.

### ACCESSORIES and OPTIONS (Available at extra cost):

- Stacking Kit
  - Security Panel for Controls
  - Tempered Glass Door Window
  - Key Lock Latch
  - Extra Wire Grids
  - Perimeter Bumper
  - Corner Bumpers
  - 1-1/2" Food Temperature Probe
  - Various Caster Options
  - HACCP Documentation (built-in USB port)
- See page E-10 for accessory details.

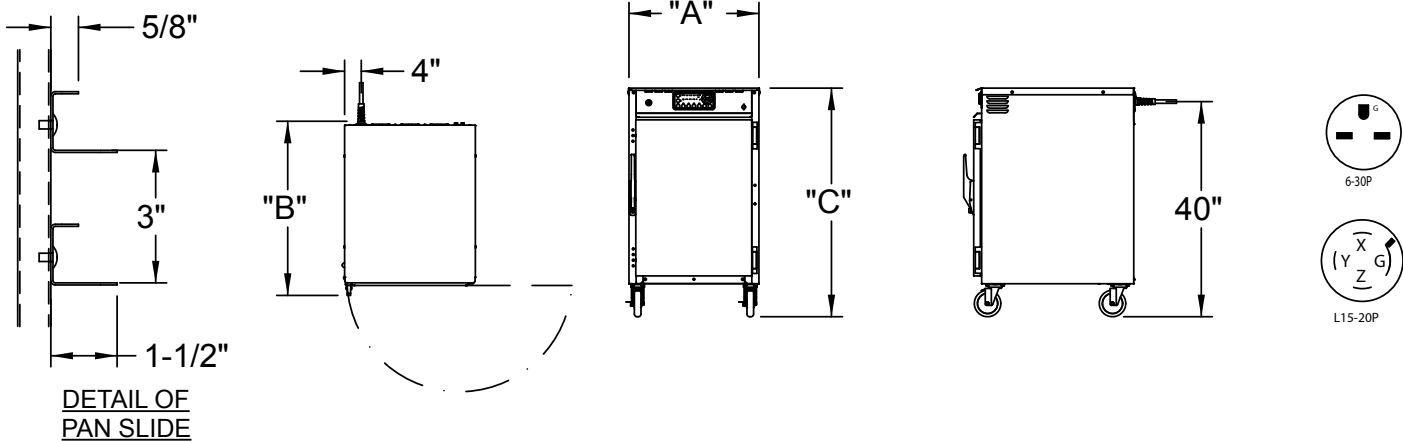

CRES COR MODEL NO.	PAN			DIM "A"	DIM "B"	DIM "C"	INSIDE DIMENSIONS				WEIGHT ACT.
	CAP	SIZE		WIDTH	DEPTH	HEIGHT	WIDTH	DEPTH	HEIGHT		
CO-151-H-189D	9	18 X 26	IN	25-3/8	37-3/4	43-3/4	18-1/4	26-1/2	28	LBS	262
		460 X 660	MM	645	960	1115	465	675	715	KG	119

When ordering bumpers, add 2" to overall dimensions.

**CABINET:**

- Body: 22 ga. stainless steel.
- Reinforcement: Internal framework of 16 ga. stainless steel.
- Insulation: Fiberglass, thermal conductivity (K factor) is .23 at 75°F. 1-1/2" in back wall, doors, base; 2" in side walls.
- Air tunnels: 20 ga. stainless steel, lift-out type, mounted on sides.
- Interior coved corners.
- Work Top: 18 ga., stainless steel.

**BASE:**

- One piece construction, .125 aluminum.
- Casters: 5" dia., swivel, modulus tires, 1-1/4 wide, load cap. 250 lbs. each, temp. range -45°/+180°F. Delrin bearings. Front casters equipped with brakes.

**DOOR:**

- Field reversible.
- Formed 22 ga. stainless steel.
- Latch: Chrome plated zinc with composite handle, ceramic magnetic type.
- Hinges: Heavy duty chrome plated zinc.
- Gasket: Perimeter type, silicone.
- Pan stop: Embossed.

**PAN SLIDES:**

- 18 ga. stainless steel channels riveted on 3" centers.
- Grids (3): Nickel chrome plated steel, raised wire 17" x 25".

**POWER REQUIREMENTS AVAILABLE:**

- 4700 Watts, 208 Volts, 60 Hz., 1 phase, 24 Amps., 30 Amp. service.
- 4700 Watts, 240 Volts, 60 Hz., 1 phase, 20 Amps., 30 Amp. service.
- 4700 Watts, 208 Volts, 60 Hz., 3 phase, 13 Amps., 20 Amp. service.
- 4700 Watts, 240 Volts, 60 Hz., 3 phase, 12 Amps., 20 Amp. service

**ELECTRICAL COMPONENTS:**

- Thermostat (roast/hold): Solid state digital control, 140°F to 350°F (176.5°C).
- Switch: ON-OFF push button type.
- Thermometer: Digital.
- Power cord: Permanent, 6 ft., 10 ga. with right angle plug.
- Heaters (6): 735 Watts each.
- Blower motors (4).
- Vent fans (3).
- Fuses (2): 6 Amp.
- Probe (1): 6" stainless steel.

**INSTALLATION REQUIREMENTS:**

- Check local vent hood codes for mobile Roast-N-Hold ovens.

**SHORT FORM SPECIFICATIONS**

Cres Cor Roast-N-Hold Half Size Convection Oven Model CO-151-H-189D. 18 ga. stainless steel, recessed control panel with digital thermostat. Cabinet and door 22 ga. stainless steel; stainless steel internal frame; coved corner interior. Fiberglass insulation in sides 2"; back, doors and base 1-1/2". High temperature anti-microbial magnetic latch. No-tip channel interior for 18" x 26" pans on 3" centers. One piece base .125 aluminum. 5" swivel modulus casters, Delrin bearings. Load capacity 250 lbs. each. 4700 Watts, \_\_\_\_\_ Volts, \_\_\_\_\_ 60 Hz., \_\_\_\_\_ Phase. 2-Year Parts / 1-Year Labor warranty. Provide the following accessories: \_\_\_\_\_ . CSA-US, CSA-C, CSA to NSF4 listed.



5925 Heisley Road • Mentor, OH 44060-1833  
 Phone: 877/CRESCOR • Fax: 440/350-7267  
 www.crescor.com

© Crescent Metal Products, Inc. 2014 All rights reserved.

*In line with its policy to continually improve its products, CRES COR reserves the right to change materials and specifications without notice.*

Litho in U.S.A.