

## INSULATED STAINLESS STEEL SUPER DUTY HOT CABINET SERIES

### FEATURES AND BENEFITS:

- Fully insulated hot cabinet keeps prepared foods at safe serving temperatures.
- Powerful, yet efficient, 1500 Watt heating system maintains the right temperature to properly hold products. Heats up to 200°F (93°C).
- Standard solid state electronic control with large, clear, easy-to-read and operate LED digital display to ensure holding at precise food temperature.
- Internal frame in body maintains structural rigidity.
- Full perimeter bumper, rear push/pull handle and dry erase panel come standard on all models.
- Stainless steel construction throughout for ease of cleaning. One piece extended base protects cabinet body.
- Super duty composite side impact panel protection with ergonomic grips on both sides prevents damage to walls; allows for easy maneuvering.
- Field reversible insulated Dutch doors prevent temperature loss. Standard with right hand hinging; left hand hinging available upon request.
- Lockable slide bolt door latches ensure the doors stay closed even during the roughest transport.
- Available in Full Size, 3/4 Size or half size units with chrome plated wire universal transport angles accommodate a large variety of pan sizes on adjustable 1-1/2" centers.
- Smooth interior coved corners prevent food particle/grease buildup.
- Heavy duty 6" poly casters, two with brakes. Provides mobility when fully loaded.



H-137-SUA-12D-SD



Standard solid state electronic control with large, clear, easy-to-read and operate LED digital display to ensure holding at precise food temperature

### ACCESSORIES and OPTIONS (Available at extra cost):

- Extra Transport Angles
- 208 or 240 Volt Service
- Upgrade to 2000 Watt Power Unit

See page B-20 for accessory details.



# H-137-SD SERIES

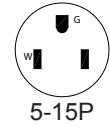
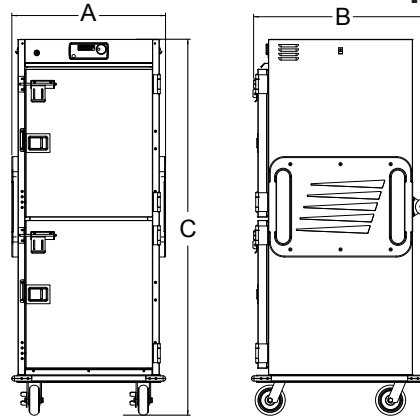
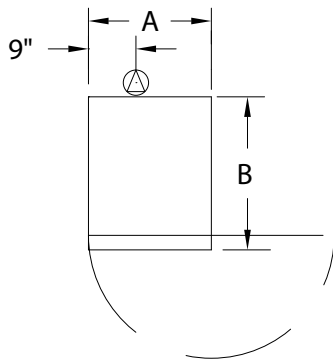
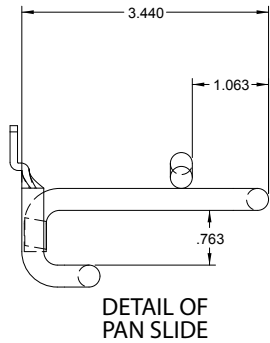

CRES COR MODEL NO.	PAN			DIM "A"	DIM "B"	DIM "C"	INSIDE DIMENSIONS				WEIGHT ACT.
	CAP/ ANGLES	SIZE		WIDTH	DEPTH	HEIGHT	WIDTH	DEPTH	HEIGHT		
H-137-SUA-12D-SD	12 SETS	SEE NOTE BELOW	IN	30-1/2	34-7/8	74-3/8	22	26-7/8	58	LBS	283
			MM	305	350	1890	560	685	1475	KG	128
H-137-SUA-9D-SD	9 SETS	SEE NOTE BELOW	IN	30-1/2	34-7/8	58-5/8	22	26-7/8	42	LBS	295
			MM	305	350	1490	560	685	1070	KG	134
H-137-SUA-6D-SD	6 SETS	SEE NOTE BELOW	IN	30-1/2	34-7/8	44-3/8	22	26-7/8	28	LBS	280
			MM	305	350	1130	560	685	715	KG	127

NOTES: Pan sizes 22" x 20" (560 x 510) Roast & Bake Pans, 10" x 20" (255 x 510) Roast & Bake Pans, 18" x 26" (460 x 660) Bun Pans, 14" x 18" (355 x 460) Service Trays, 12" x 20" (305 x 510) Steam Table Pans. Refer to Pan Size Chart at end of section.



Gold indicates our Best Insulated Hot Cabinets with the best warranty in the industry. 3-Year Parts / 1-Year Labor.

## CABINET:

- Body: 22 ga. stainless steel.
- Reinforcement: Internal framework of 18 ga. 304 stainless steel.
- Insulation: Fiberglass, thermal conductivity (K factor) is .23 at 75°F. 1-1/2" in doors, base top; 2" in sidewalls.
- Air tunnels: 22 ga. stainless steel; lift-out type, mounted on sides.
- Push/pull handle: stainless steel with end bumpers; rear mounted.
- Interior coved corners.
- Super Duty composite side impact panel with ergonomic grips.
- Supplied with magnetic white erasable board, 12" x 12".

## BASE:

- One piece construction, .125 aluminum; extended in rear for toe kick.
- Casters: 6" dia., poly tires, 1-1/4 wide, load cap. 300 lbs. each, temp. range -30°/+180°F. Sealed ball bearings; permanently lubricated. Front casters equipped with brakes.
- Perimeter bumper: 1" non-marking gray rubber.

## DUTCH DOORS:

- Field reversible.
- Formed 22 ga. stainless steel.
- Hinges: 11 ga. stainless steel, butt type.
- Gaskets: Perimeter type, silicone.
- Pan stop: Embossed.
- Latches: Polished stainless steel, slam type; flush mounted.
- Transport Latch: 12 ga. stainless steel slide with lockable hasp.

## PAN SLIDES:

- Wire transport angles (.306 dia.), nickel chrome plated steel, mounted on lift-off posts.
- Spaced on 4-1/2" centers; adjustable on 1-1/2" centers.

## HOT UNIT COMPONENTS:

- Thermostat: Solid state digital display control, room ambient to 200°F (93°C).
- Switch: ON-OFF push button type.
- Power cord: Permanent, 10 ft., 14/3 ga.
- Heater: 1470 Watts (960 Watts for -UA6D)
- Blower motor.
- Vent Fan.
- Thermometer: Digital.

## POWER REQUIREMENTS:

- For H137SUA9D and H137SUA12D: 1500 Watts, 120 Volts, 60 Hz., single phase, 12 Amps., 15 Amp. service.
- For H137SUA6D: 1000 Watts, 120 Voltes, 60 Hz., single phase, 8.3 Amps., 15 Amp. service.

## SHORT FORM SPECIFICATIONS

Cres Cor Insulated Hot Cabinet Model H-137-SUA-\_\_\_D. Solid state electronic controlled time and temperatures. Cabinet 22 ga. stainless steel; stainless steel internal frame. (\_\_\_) sets wire transport angles for multiple pan sizes, adjustable spacing every 1-1/2". Field reversible Dutch doors, 22 ga. stainless steel. Fiberglass insulation in sides, 2"; doors, base, top 1-1/2". Interior coved corners. 1500 or 1000 Watt, 120 Volt power unit. One piece insulated base, .125 aluminum. 6" poly casters, ball bearings. Load capacity 300 lbs. each. 3-Year Parts / 1-Year Labor warranty. Provide the following accessories: \_\_\_\_\_. NSF, CSA-US, CSA-C listed. Energy Star Qualified.



5925 Heisley Road • Mentor, OH 44060-1833  
Phone: 877/CRESCOR • Fax: 440/350-7267  
www.crescor.com

© Crescent Metal Products, Inc. 2012 All rights reserved.

*In line with its policy to continually improve its products, CRES COR reserves the right to change materials and specifications without notice.*

Litho in U.S.A.