

INSULATED CORRECTIONAL HOT CABINET MODEL H-137-UA-12DSDZ

FEATURES AND BENEFITS:

- Fully insulated hot cabinet keeps prepared foods at serving temperatures.
- Powerful, yet efficient, 1500 Watt heating system maintains the right temperature to properly hold products. Heats up to 200°F (93°C).
- Standard solid state electronic control with large, clear, easy-to-read and operate LED digital display to ensure holding at precise food temperature
- Stainless steel and Lexan security panel protects controls.
- Internal frame in body maintains structural rigidity.
- Body constructed of non-corrosive, Hi-Tensile aluminum for strength and ease of mobility. One piece extended base protects cabinet body.
- Smooth interior coved corners prevent food particle/grease buildup.
- Field reversible insulated Dutch doors prevent temperature loss. Silicone door gaskets for proper seal.
- Standard with right hand hinging; left hand hinging available upon request. Doors swing 270° on 11 ga. stainless steel hinges.
- High temperature ceramic magnetic latches with key locks secure doors. Lock hasp provided.
- Recessed push/pull handles on both sides prevents damage to walls; allows easy maneuvering.
- Twelve sets of stainless steel universal angles accommodate a large variety of pan sizes, riveted on 4-1/2" centers.
- Heavy duty 5" swivel casters, two with brakes. Provides mobility when fully loaded.



H-137-UA-12DSDZ



ACCESSORIES and OPTIONS (Available at extra cost):

- Corner Bumpers
- Perimeter Bumper
- Various Caster Options
- 208 or 240 Volt Service
- Upgrade to 2000 Watt Power Unit

See page B-20 for accessory details.

H-137-UA-12DSDZ

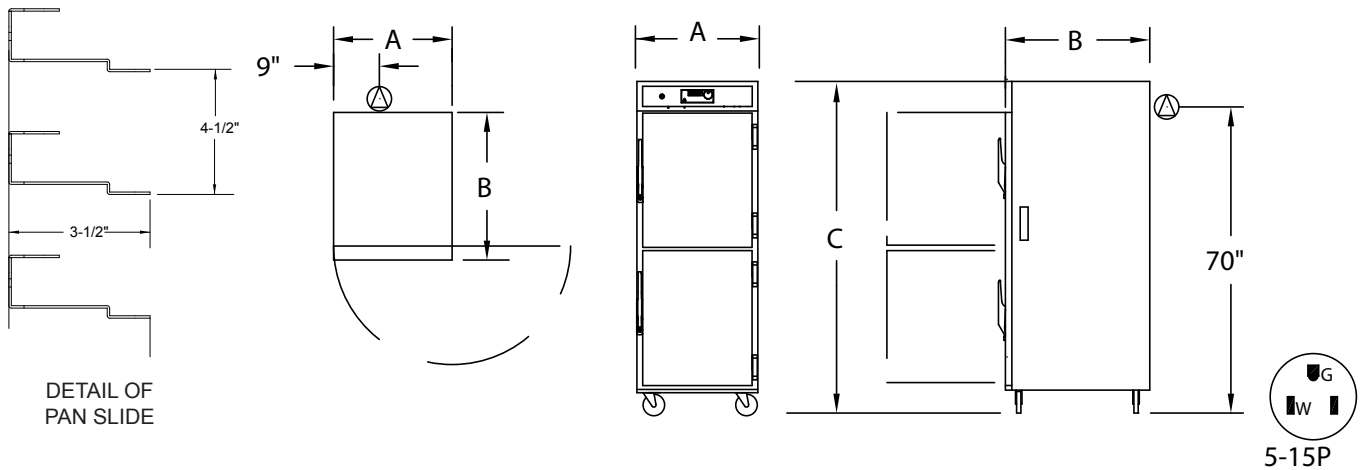

CRES COR MODEL NO.	PAN			DIM "A"	DIM "B"	DIM "C"	INSIDE DIMENSIONS				WEIGHT ACT.
	CAP/ ANGLES	SIZE		WIDTH	DEPTH	HEIGHT	WIDTH	DEPTH	HEIGHT		
H-137-UA-12DSDZ	12 SETS	SEE NOTE BELOW	IN	28-3/4	32-3/4	73	22	26-7/8	58	LBS	283
			MM	730	835	1855	560	685	1475	KG	128

NOTES: 1. Pan sizes 22" x 20" (560 x 510) Roast & Bake Pans, 10" x 20" (255 x 510) Roast & Bake Pans, 18" x 26" (460 x 660) Bun Pans, 14" x 18" (355 x 460) Service Trays, 12" x 20" (305 x 510) Steam Table Pans.
 2. When ordering bumpers, add 2" to overall dimensions.

ALL EXPOSED FASTENERS ARE TAMPER PROOF.

CABINET:

- Body: .063 aluminum.
- Reinforcement: Internal framework of 18 ga. 304 stainless steel.
- Insulation: Fiberglass, thermal conductivity (K factor) is .23 at 75°F. 1-1/2" in doors, base top; 2" in sidewalls.
- Air tunnels: .063 aluminum; mounted on sides. Removable with special tools.
- Push/pull handles (2): 5" vertical; recessed.
- Interior coved corners.

BASE:

- One piece construction, .125 aluminum.
- Casters: 5" dia., swivel, modulus tires, 1-1/4 wide, load cap. 250 lbs. each, temp. range -45°/+180°F. Delrin bearings. Front casters equipped with brakes.

DUTCH DOORS:

- Field reversible.
- Formed .063 aluminum.
- Latches: Chrome plated zinc, high temperature ceramic magnetic type with key lock handles.
- Hinges: 11 ga. stainless steel butt type; 270° swing.
- Gaskets: Perimeter type, silicone.
- Pan stops: Embossed.
- Lock Hasp

PAN SLIDES:

- Angles: .060 stainless steel; riveted to posts on 4-1/2" centers.
- Removable with tools.

HOT UNIT COMPONENTS:

- **Security Panel:** 18 ga. stainless steel with 3/16" polycarbonate window and key lock.
- **Thermostat:** Solid state digital display control, room ambient to 200°F (93°C).
- **Switch:** ON-OFF push button type.
- **Power cord:** Permanent, 10 ft., 14/3 ga.
- **Heater:** 1470 Watts.
- **Blower motor.**
- **Vent Fan.**
- **Thermometer:** Digital.

POWER REQUIREMENTS:

- 1500 Watts, 120 Volts, 60 Hz., single phase, 12 Amps., 15 Amp. service.

SHORT FORM SPECIFICATIONS

Cres Cor Correctional Insulated Hot Cabinet Model H-137-UA-12DSDZ. Cabinet body .063 aluminum; stainless steel internal frame. (12) sets stainless steel universal angles for multiple pan sizes on 4-1/2" centers. Field reversible Dutch doors, .063 aluminum.* Fiberglass insulation in sides, 2"; doors, base, top 1-1/2". Interior coved corners. Hose out cleaning capability. 1500 Watt, 120 Volt power unit. One piece insulated base, .125 aluminum. 5" swivel modulus casters, Delrin bearings. Load capacity 250 lbs. each. 1-Year Parts / 90-Day Labor warranty. Provide the following accessories: _____ . NSF, CSA-US, CSA-C listed.
 * All exposed fasteners are tamper proof.



5925 Heisley Road • Mentor, OH 44060-1833
 Phone: 877/CRESCOR • Fax: 440/350-7267
 www.crescor.com

© Crescent Metal Products, Inc. 2012 All rights reserved.

In line with its policy to continually improve its products, CRES COR reserves the right to change materials and specifications without notice.

Litho in U.S.A.