

**INSULATED HALF-SIZE
STAINLESS STEEL HOT CABINETS
H-339-SS-128C
(FOR 12" X 20" PANS)**

FEATURES AND BENEFITS:

- Fully insulated half-size hot cabinet keeps prepared foods at serving temperatures.
- Powerful, yet efficient, 900 Watt heating system maintains the right temperature to properly hold products. Heats up to 200°F (93°C).
- Internal frame in body and door maintains structural rigidity.
- Stainless steel construction throughout for ease of cleaning. One piece extended base protects cabinet body.
- Safety-conscious anti-microbial latch protect against spreading germs.
- Insulated field reversible door for flexibility. Standard with right hand hinging; left hand hinging available upon request.
- Magnetic latch for “easy open”; twist-lock catch secures door during transport. Latch and hinges mounted inboard.
- Removable wire pan supports for easy cleaning hold 12" x 20" pans on 2-3/4" centers.
- Pan stops on inside of door and back allow for proper air flow.
- Convenient lift handles fold flat against sides of cabinet.
- Heavy duty 5" swivel casters, two with brakes. Provides mobility when fully loaded.
- Cabinets can be stacked for flexibility; specify optional stacking kit.



H-339-SS-128C



NSF/ANSI 4



c US

**ACCESSORIES and OPTIONS
(Available at extra cost):**

- Key Lock Handle
- Stacking Kit
- Pan Support Interior For 13" x 18" Trays
- Corner Bumpers
- Perimeter Bumper
- Various Caster Options
- Digital Thermometer
- 240 Volt Service

See page B-20 for accessory details.

H-339-SS-128C

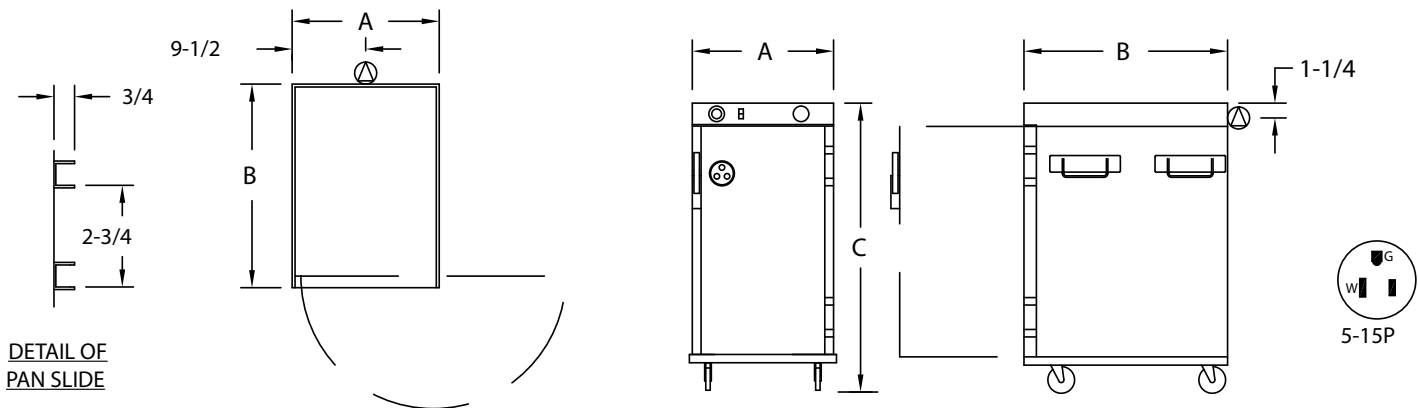

CRES COR MODEL NO.	PAN			DIM "A"	DIM "B"	DIM "C"	INSIDE DIMENSIONS			WEIGHT ACT.	
	CAP	SIZE		WIDTH	DEPTH	HEIGHT	WIDTH	DEPTH	HEIGHT		
H-339-SS-128C	8	12 x 20	IN	18-7/8	27-1/4	36-11/16	13-3/16	21-1/4	24-7/8	LBS	155
		305 x 510	MM	480	695	935	335	540	635	KG	70

NOTES: 1. When ordering bumpers, add 2" to overall dimensions.
2. When stacking two cabinets, width will increase to 24-5/8".

ALL CONSTRUCTION IS RIVETED, WELDED AND FINISHED.

CABINET:

- Body: 22 ga. stainless steel.
- Reinforcement: Internal framework of channels, 1 x 3/4 x .125.
- Insulation: Fiberglass, thermal conductivity (K factor) is .23 at 75°F. 1-1/2" in walls; 1" in door, top and bottom.
- Pan stop channels: Mounted to inside rear of cabinet and door.
- Bail handles (4): Two mounted to each side.

BASE:

- One piece construction, .190 aluminum.
- Casters: 5" dia., swivel, modulus tires, 1-1/4 wide, load cap. 250 lbs. each, temp. range -45°/+180°F. Delrin bearings. Front casters equipped with brakes.

DOOR:

- Field reversible.
- Formed 22 ga. stainless steel.
- Latch: Chrome plated zinc with composite handle, magnetic type; mounted inboard.
- Hinges: Heavy duty chrome plated zinc; mounted inboard.
- Gasket: Perimeter type, silicone.
- Transport latch.
- Vent: Adjustable.

PAN SLIDES:

- Flat wire racks, .104 x 5/8 nickel chrome plated steel, spaced on 2-3/4" centers.

ELECTRICAL COMPARTMENT:

- Cover: Formed 18 ga. stainless steel fastened to cabinet top.
- Control panel: Formed .063 aluminum; black front.
- Thermostat: Electro-mechanical, room ambient to 200°F (93°C).
- Switch: Lighted ON-OFF rocker type.
- Power cord: Removable, 6 ft., 14/3 ga. with molded straight plug.
- Heaters (3): 300 Watts each.
- Thermometer.

POWER REQUIREMENTS:

- 900 Watts, 120 Volts, 60 Hz., single phase, 7.5 Amps., 15 Amp. service.

SHORT FORM SPECIFICATIONS

Cres Cor Insulated Half-Size Hot Cabinet Model H-339-SS-128C. Cabinet and door 22 ga. stainless steel; reinforced with channel frame. Field reversible door. Fiberglass insulation in walls 1-1/2"; door, top and bottom 1". Welded and finished .190 aluminum base. (3) 300 Watt inner wall heaters, 120 Volts. Removable pan supports for (8) 12" x 20" pans on 2-3/4" centers. Two bail handles on each side. 5" swivel modulus casters, Delrin bearings. Load capacity 250 lbs. each. 2-Year Parts / 1-Year Labor warranty. Provide the following accessories: _____ CSA-US, CSA-C, CSA to NSF4 listed.



5925 Heisley Road • Mentor, OH 44060-1833
Phone: 877/CRESCOR • Fax: 440/350-7267
www.crescor.com

© Crescent Metal Products, Inc. 2011 All rights reserved.

In line with its policy to continually improve its products, CRES COR reserves the right to change materials and specifications without notice.

Litho in U.S.A.