

INSULATED STAINLESS STEEL ROLL-IN HOT CABINET WITH RACK MODEL RH-1332-D

FEATURES AND BENEFITS:

- Roll-In-Rack designed for moving school pre-packed meals in baskets from prep area, central kitchen, commissary, cooler, oven then hold until ready to serve.
- Fully insulated Roll-In Hot Cabinet designed for holding school pre-packed meals at safe serving temperatures.
- Powerful, yet efficient, 3000 Watt heating system maintains the right temperature to properly hold products. Heats up to 200°F (93°C).
- Standard solid state electronic control with large, clear, easy-to-read and operate LED digital display to ensure holding at precise food temperature.
- Stainless steel construction throughout for ease of cleaning. One piece extended base protects cabinet body.
- High temperature ceramic magnetic latch for "easy open"; twist-lock catch keeps door securely closed.
- Capacity: 32 school baskets, 13" x 26".



RH-1332-D



New, easier to use, easy-to-read and operate LED digital display ensures holding at precise food temperatures and moisture content.

ACCESSORIES and OPTIONS (Available at extra cost):

- Security Panel for Controls
- Key Lock Latch
- Wire Baskets
- Extra Roll-In Rack



RH-1332-D

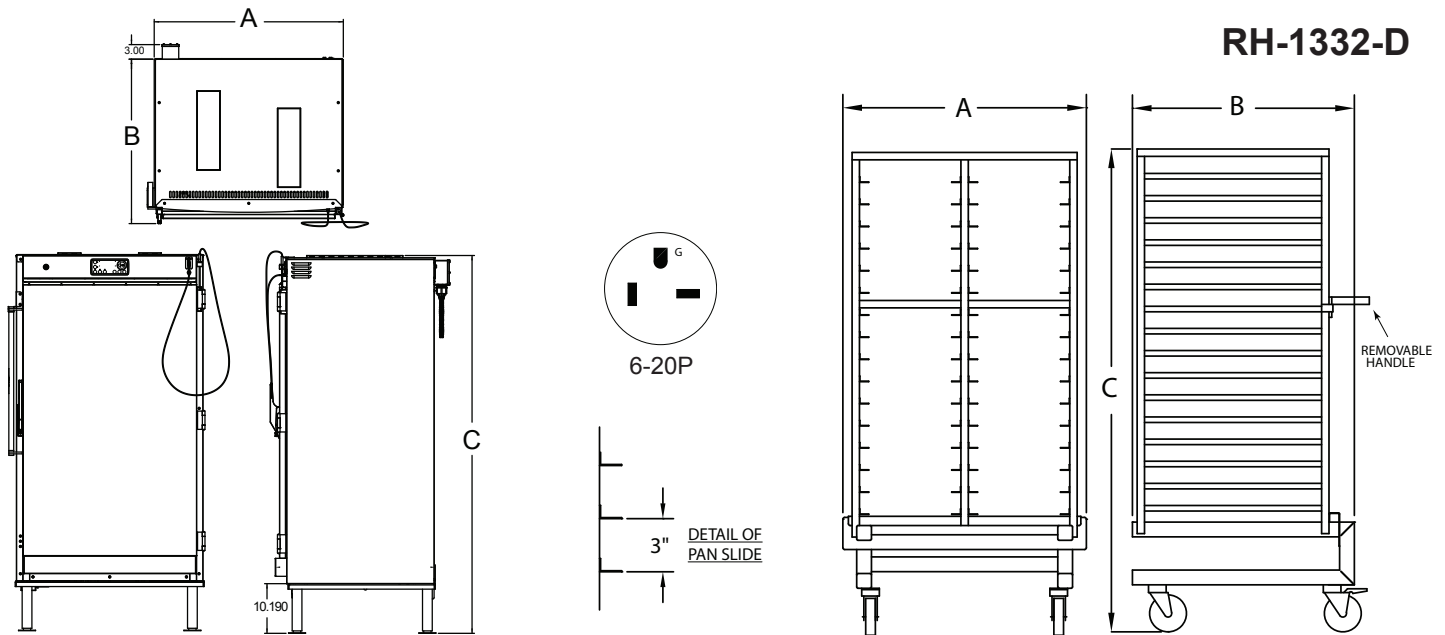

CRES COR MODEL NO.	CAPACITY / SIZE		DIM "A"	DIM "B"	DIM "C"	INSIDE DIMENSIONS			WEIGHT ACT.		
			WIDTH	DEPTH	HEIGHT	WIDTH	DEPTH	HEIGHT			
RH-1332-D	1 RACK	IN	39	33-7/8	77-5/8	32-1/8	28-3/8	56-1/4	LBS	367	
		MM	991	860	1972	816	721	1429	KG	166	
ROR-201-SBS-1332-D	32 BASKETS	13 X 26	IN	35-5/8	30-1/4	65-1/2	13-5/8	26	49-1/2	LBS	131
		330 X 660	MM	905	768	1663	346	660	1257	KG	59

INSIDE RACK WIDTH DIMENSION IS FOR ONE SIDE.

CABINET:

- Body: 22 ga. stainless steel.
- Inner liner: Formed 22 ga. stainless steel.
- Reinforcement: Internal framework of 14 ga. stainless steel channels, welded.
- Insulation: Fiberglass, thermal conductivity (K factor) is .23 at 75°F. 1-1/2" in back wall, door, base; 2" in side walls.
- Air tunnels: 20 ga. stainless steel, lift-out type, mounted on inner sides.

BASE:

- One piece construction, .190 aluminum.
- Legs: Heavy duty polished stainless steel 2" O.D. adjustable for leveling over.

DOOR:

- Field reversible.
- Formed 22 ga. stainless steel.
- Latch: Chrome plated high pressure die cast zinc, composite handle, ceramic magnetic.
- Hinges: Heavy duty chrome plated die cast zinc, mounted inboard.
- Door Gaskets: Perimeter type, silicone.

HOT UNIT COMPONENTS:

- Thermostat (holding): Solid state digital display control, room ambient to 200°F (93°C).
- Switch: ON-OFF push button type.
- Power cord: Permanent, 10 ft., 12/3 ga.
- Heater: 3000 Watts for holding.
- Blower motor.
- Vent fan.
- Thermometer: Digital.

POWER REQUIREMENTS AVAILABLE:

3000 Watts, 208 Volts, 1 Phase, 60 Hz., 20 Amp. Service

ROLL-IN RACK (ROR-201-SBS-1332-D):

- Angles (16 sets): Formed, permanently attached, spaced on 3" centers.
- 5" dia. swivel, modulus tires, 1-1/4" wide, load cap. 250 lbs. each, temp. range -45°/+180°F. Delrin bearings. Two casters equipped with brakes.
- Capacity: 2 baskets side-by-side, 16 baskets high, 32 baskets total, 320 meals total.

SHORT FORM SPECIFICATIONS

Cres Cor Roll-In Hot Cabinet Model RH-1332-D. 18 ga. stainless steel, recessed control panel. Cabinet and Dutch doors 22 ga. stainless steel; stainless steel internal frame; coved corner interior. Fiberglass insulation in sides 2"; back, doors and base 1-1/2". High temperature anti-microbial magnetic latches. One piece base .190 aluminum. 2" dia. stainless steel legs. Includes Cres Cor Roll-In Rack Model ROR-201-SBS-1332-D: 16 angles on 3" centers; holds 32 baskets. 5" swivel modulus casters, Delrin bearings. Load capacity 250 lbs. each, temperature -45 to +180°F. 120 Volts, 60 Hz., 1 Phase. 2 year parts warranty. Provide the following accessories: _____ . CSA-US, CSA-C, CSA to NSF4 listed.



5925 Heisley Road • Mentor, OH 44060-1833
 Phone: 877/CRESCOR • Fax: 440/350-7267
 www.crescor.com

© Crescent Metal Products, Inc. 2015 All rights reserved.

In line with its policy to continually improve its products, CRES COR reserves the right to change materials and specifications without notice.

Litho in U.S.A.