

## QUIK THERM™ 12 KW RETHERM OVEN MODEL RO-151-FW-1332D

### FEATURES AND BENEFITS:

- Roast, cook, bake, rethermalize and hold with precise temperature and humidity control. Power boosting switch allows end user flexibility to increase or reduce air flow.
- Moist heat, dry heat or a combination of both allows for a variety of food preparation and holding.
- Full 12,000 Watts of power allows for rethermalization of prepared meals or bulk items. Maximum temperature 350°F. (176.5°C.).
- 2000 Watt water heater with separate control and low water indicator.
- Standard with automatic water fill system and low water indicator. LED and water heater shut off when water at critically low level.
- Standard solid state electronic control with large, clean, easy-to-read and operate LED digital display to ensure holding at precise food temperatures and moisture content.
- 18 factory or field programmed retherm & hold cycles. Each programmed menu can be customized for exact time, temperature and humidity needs.
- AquaTemp system maintains optimum food texture through continuous monitoring of both temperature and humidity. Temperature and humidity values are measured, displayed and controlled through intuitive solid state controller. Air temperature is prioritized over humidity to ensure food safety.
- Standard with probe cooking, includes one 1-1/2" food temperature probe.
- Non-venting oven, permitted by most local codes, provides easy, inexpensive installation.
- Stainless steel construction and smooth interior coved corners for ease of cleaning and prevent food particle/grease buildup.
- Field reversible insulated Dutch doors prevent temperature loss. Silicone door gaskets for proper seal. High temperature ceramic magnetic latches for "easy open" and security during transport.
- Safety conscious anti-microbial latches protect against spreading germs. Standard with right hand hinging; left hand hinging available upon request.
- Non-corrosive stainless steel wire universal angles accommodate a large variety of pan sizes on adjustable 1-1/2" spacing. Supplied with 18 sets of angles.
- Integral drip trough on front keeps traffic area dry, safer.
- Heavy duty 5" swivel casters, two with brakes. Provides mobility when fully loaded.

### POWER UNIT OPTIONS:

- 12,000 Watts, 208 Volts, 3 Phase, 60 Hz.
- 12,000 Watts, 240 Volts, 3 Phase, 60 Hz.



RO-151-FW-1332D

### ACCESSORIES and OPTIONS (Available at extra cost):

- 6" Food Temperature Probe
- Security Panel for Controls
- Tempered Glass Door Windows
- Key Lock Latches
- Wire Grids
- Extra Universal Angles
- Side and Rear Bumpers
- HACCP Documentation (built in USB port)

See page E-10 for accessory details.

**aquatemp** 

**RO-151-FW-1332D**

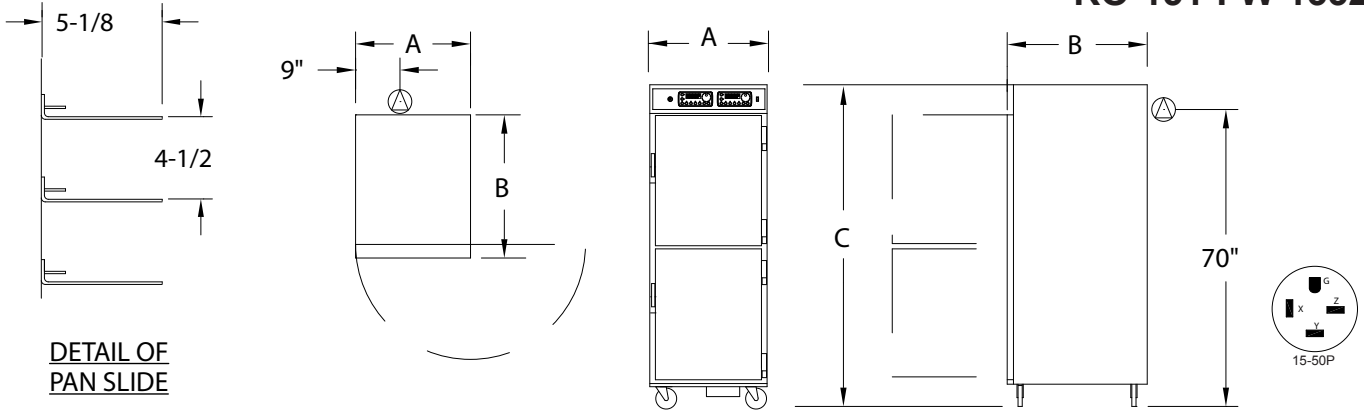

| CRES COR MODEL NO. | PAN         |           |    | DIM "A" | DIM "B" | DIM "C"  | INSIDE DIMENSIONS |        |        | WEIGHT ACT. |     |
|--------------------|-------------|-----------|----|---------|---------|----------|-------------------|--------|--------|-------------|-----|
|                    | CAP/ ANGLES | SIZE      |    | WIDTH   | DEPTH   | HEIGHT   | WIDTH             | DEPTH  | HEIGHT |             |     |
| RO-151-FW-1332D    | 18          | 18 x 26   | IN | 34-7/8  | 35-1/8  | 73-11/16 | 28-3/4            | 26-7/8 | 58     | LBS         | 392 |
|                    |             | 460 x 660 | MM | 885     | 895     | 1870     | 730               | 685    | 1475   | KG          | 178 |
|                    | 32          | 13 x 26   | IN |         |         |          |                   |        |        |             |     |
|                    |             | 330 x 660 | MM |         |         |          |                   |        |        |             |     |

NOTES: 1. Pan sizes 22" x 20" (560 x 510) Roast & Bake Pans, 10" x 20" (255 x 510) Roast & Bake Pans, 18" x 26" (460 x 660) Bun Pans, 14" x 18" (355 x 460) Service Trays, 12" x 20" (305 x 510) Steam Table Pans. Refer to Pan Size Chart at end of section.  
 2. When ordering bumpers, add 2" to overall dimensions.

**CABINET:**

- Body: 22 ga. stainless steel.
- Reinforcement: Internal framework of 18 ga. stainless steel.
- Insulation: Fiberglass, thermal conductivity (K factor) is .23 at 75°F. 1-1/2" in doors, top, base; 2" in sidewalls.
- Air tunnels: 22 ga. stainless steel; lift-out type, mounted on sides.
- Interior coved corners.
- Automatic water fill hook-up under rear of base.

**BASE:**

- One piece construction, .125 aluminum.
- Drip trough: Formed 18 ga. stainless steel mounted to front of cabinet; removable drip pan.
- Casters: 5" dia., swivel, modulus tires, 1-1/4 wide, load cap. 250 lbs. each, temp. range -45°/+180°F. Delrin bearings. Front casters equipped with brakes.

**DUTCH DOORS:**

- Field reversible.
- Formed 22 ga. stainless steel.
- Latches: Chrome plated steel, high temperature ceramic magnetic type.
- Hinges: Heavy duty chrome plated steel.
- Gaskets: Perimeter type, silicone.
- Pan stops: Embossed.

**PAN SLIDES:**

- Stainless steel wire universal angles (.306 dia.), mounted on lift-out posts.
- 18 sets of angles; adjustable on 1-1/2" centers.

**POWER REQUIREMENTS AVAILABLE:**

- 12,000 Watts, 208 Volts, 60 Hz., 3 phase, 50 Amp. service.
- 12,000 Watts, 240 Volts, 60 Hz., 3 phase, 50 Amp. service

**HOT UNIT COMPONENTS:**

- Thermostat (retherm/hold): Solid state digital control, 140°F to 350°F (176.5°C).
- Thermostat (humidity): Solid state digital control, room ambient to 95%.
- Switch: ON-OFF push button type.
- Power cord: Permanent, 10 ft., 12/3 ga. with 15-50 plug.
- Heaters: 2000 Watts each.
- Switch: (1) Air volume.
- Blower motors: (6).
- Vent fans: (2).
- Water pan: 4 gallons; 16 ga. 304 stainless steel with 1850 Watt heater for humidity.
- Fuses: (2) 6 Amp.
- Probe: (1) 1-1/2", stainless steel.

**INSTALLATION REQUIREMENTS:**

- Check local vent hood codes for mobile Roast-N-Hold ovens.

**SHORT FORM SPECIFICATIONS**

Cres Cor QuikTherm™ AquaTemp Retherm Oven Model RO-151-FW-1332D. 20 ga. stainless steel, recessed control panel. Cabinet 22 ga. stainless steel. Stainless steel internal frame; coved corner interior. 16 ga. stainless steel 4 gallon water reservoir with automatic water fill hook-up. Fiberglass insulation in sides 2"; back, doors and base 1-1/2". 22 ga. stainless steel door, high temperature anti-microbial magnetic latches, heavy duty hinges. (18) sets universal angles for multiple pan sizes and spacing. One piece base .125 aluminum. 5" swivel modulus casters, Delrin bearings. Load capacity 250 lbs. each. 12,000 Watts, \_\_\_\_\_ Volts, 60 Hz., 3 Phase. 2-Year Parts / 1-Year Labor warranty. Provide the following accessories: \_\_\_\_\_ .



5925 Heisley Road • Mentor, OH 44060-1833  
 Phone: 877/CRESCOR • Fax: 440/350-7267  
 www.crescor.com

© Crescent Metal Products, Inc. 2012 All rights reserved.

*In line with its policy to continually improve its products, CRES COR reserves the right to change materials and specifications without notice.*

Litho in U.S.A.