

ROR201SBS1332 for RR1332

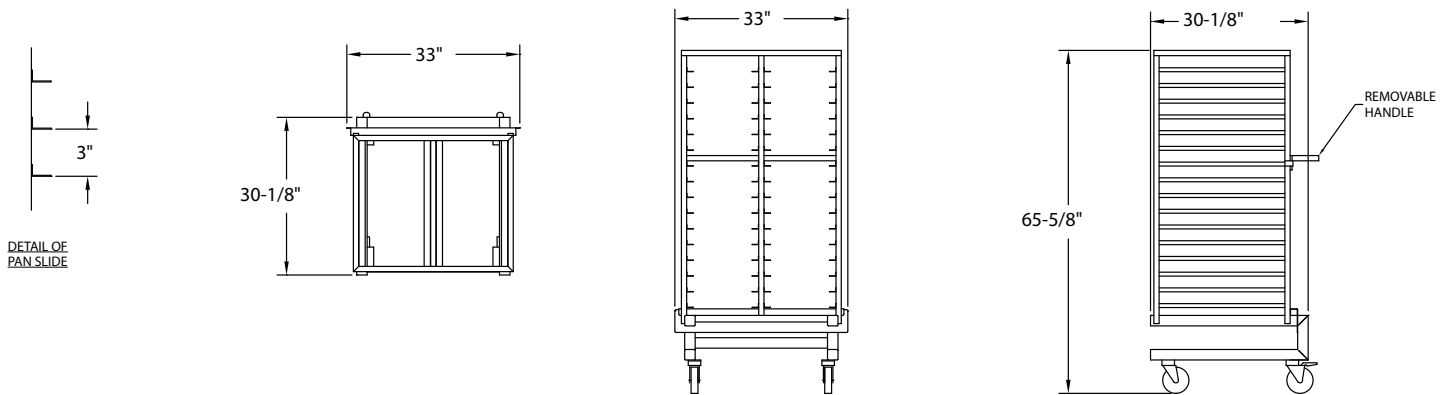

ROLL-IN RACK:

- Angles (16 sets): Formed, permanently attached, spaced on 3" centers.
- 5" dia. swivel, modulus tires, 1-1/4" wide, load cap. 250 lbs. each, temp. range -45°/+180°F. Delrin bearings. Two casters equipped with brakes.
- Capacity: 2 baskets side-by-side, 16 baskets high, 32 baskets total, 320 meals total.
- Total weight capacity for retherm: Maximum unit loading equals 150 lbs. equally distributed among 32 baskets at 4.66 lbs./basket, per Annex B in NSF Standard 4 "Performance Test Methods for Rethermalization Equipment".
- NOTE: BASKETS NOT INCLUDED.



5925 Heisley Road • Mentor, OH 44060-1833
Phone: 877/CRESCOR • Fax: 440/350-7267
www.crescor.com

© Crescent Metal Products, Inc. 2009 All rights reserved.

*In line with its policy to continually improve its products,
CRES COR reserves the right to change materials and
specifications without notice.*

Litho in U.S.A.