

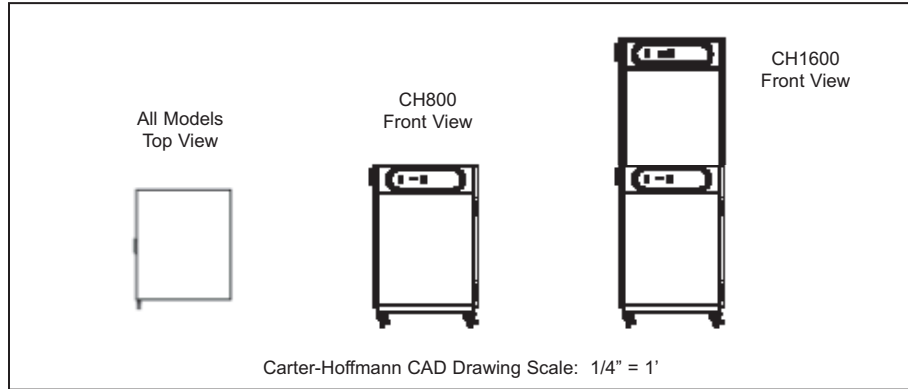

CH800 & CH1600 COOK & HOLD CABINETS

Cook to Time or Product Temperature



Model Number	Capacity* 18"x26" Trays	Approximate Meat Capacity	Spacing		Inside Working Height		Overall Dimensions			Caster Diameter		Shipping Weight				
			in	mm	in	mm	Height in	Depth mm	Width in	in	mm	lbs	kg			
<input type="checkbox"/> CH800	8	120 lbs	2 ³ / ₄	70	22	559	39 ¹ / ₂	1003	32 ³ / ₄	832	26 ¹ / ₈	664	3	76	275	125
<input type="checkbox"/> CH1600	16**	240 lbs	2 ³ / ₄	70	22*	559	76 ³ / ₈	1940	32 ³ / ₄	835	26 ¹ / ₈	664	5	127	420	420

*Can accommodate 12"x20"x2.5" pans, end-loaded (1 per shelf), on optional wire shelves; Max. capacity, CH800: 8 pans, CH1600: 16 pans.
**8 per cavity.

CONSTRUCTION... Completely welded cabinet construction with outer cabinet welded to base. All seams turned in to eliminate raw edges. Gray vinyl bumper set in channel on each side of cabinet.

CABINET MATERIAL... All stainless steel double-wall, insulated construction.

BASE FRAME... stainless steel full depth caster bolsters with stainless steel perimeter supports welded to bolsters.

CASTERS... Casters with rubber tread. Double ball bearing swivel. Zerk grease fittings. Plate mounted and bolted to base. Two casters fitted with brakes. CH1600: 5" dia., CH800: 3" dia.

INSULATION... 2" thick high density continuous wrap-around fiberglass insulation.

DOOR... Welded double panel stainless steel door; turned-in seam pocket construction. Filled with 2" thick high density fiberglass insulation. Field reversible. One door for each cavity on CH1600.

HINGES... Adjustable self-closing, edgmount hinges with chrome plate finish.

GASKET... High temperature silicone gasket mounted to cabinet.

LATCH... Heavy-duty edgmount latch with magnetic catch.

TRAY RACK ASSEMBLIES... Removable stainless steel tray racks with solid stainless steel angle slides. Slides welded to assemblies and spaced on 2.75" centers.

THERMOMETER... Digital thermometer with remote sensing bulb for cabinet operating temperature. Digital temperature displays in temperature window of current mode (cook or hold) by pushing "view actual temp" key.

CONTROLS... User-friendly digital controls with digital readout displays for settings. Includes meat probe. Cook to time or product temperature. Master on/off switch with "start/cancel" button for cook cycles. Touchpad to view actual temperature. Separate controls & displays for cook temperature and hold temperature. Eighteen hour digital timer display shows cook temperature in count down mode during cook cycle. During hold cycle, automatically switches to count up. CH1600 features dual cavity with dual controls.

HEATING SYSTEM... Top mounted blower heater for even heat distribution. High impedance protected, internally cooled fan motor. Full range thermostat and on/off switch with power indicating light and "start/cancel" button.

HEAT DUCT SYSTEM... Side-mounted precision engineered interior heat duct system to provide gentle heat circulation throughout cabinet to caramelize roasts for less food shrinkage and more attractive appearance.

ELECTRICAL CHARACTERISTICS...

All models are 60hz, single phase.

Model	Volts	Watts	Amps	Plug
CH800	240	3200	13.3	NEMA 6-20P
CH1600	240	6200	25.8	NEMA 6-30P

PERFORMANCE... Capable of slow cooking to a maximum temperature of 325°F (161° C). Capable of holding at a range of 100°F (38°C) to 200°F (93°C). Preheat to 160°F (71° C) in approximately 25 minutes. Temperature variance less than 5°F(3°C), top to bottom.

ACCESSORIES/OPTIONS...

- Legs in lieu of casters
- Menu card holder
- Tamper resistant fasteners
- Locking door latch
- 208 volt operation, all models
- 120 volt operation, CH800 only
- 230 volt CE operation
- Wire shelves to accommodate 12"x20"pans

Specifications subject to change through product improvement & innovation.

CARTER-HOFFMANN

1551 McCormick Ave., Mundelein, IL 60060
(847) 362-5500 • (800) 323-9793 • Fax (847) 367-8981
www.carter-hoffmann.com



FEATURES & BENEFITS

1551 McCormick Avenue, Mundelein, Illinois 60060
Tel. (847)362-5500 • (800)323-9793 • Fax (847)367-8981
www.carter-hoffmann.com



CH800 & CH1600 COOK & HOLD CABINETS

Since 1947, Foodservice Equipment That Delivers!

CARAMELIZATION IS KEY... Precision engineered heating system with gentle, consistent blower heat caramelizes roasts and seals in juices for minimal shrinkage and more portions. And it produces a more natural, attractive product with superior taste.

CONVECTION HEATING SYSTEM... Fully contained heater with forced air cooking. Side air ducts for optimal air flow and even circulation throughout cabinet.

VENTILATION HOOD NOT REQUIRED... Because these cabinets cook at a lower temperature than standard convection ovens, a hood is not needed (check local codes).

ALL STAINLESS STEEL CONSTRUCTION... Welded, turned-in seam construction for long durable life and ease of cleaning and safety.



CH1600



EASY-TO-USE DIGITAL CONTROLS... Control cooking and holding with separate dial controls and digital display. Cook according to time or according to product temperature with meat probe. Temperature range of 100°F to 200°F for hold cycle and 100°F to 325°F for cook cycle. Eighteen hour timer counts down in cook cycle. When cook cycle is over, cabinet automatically switches to hold cycle and timer counts up.

**MEAT
PROBE
INCLUDED!**

