



# DF Series Doorless Holding Cabinets Universal Shelves

CARTER-HOFFMANN



FOOD SERVICE EQUIPMENT  
HEATED HOLDING CABINETS

# SPECIFICATIONS

Printed in U.S.A. E92 1010  
Carter-Hoffmann is a trademark  
of Carter-Hoffmann LLC.

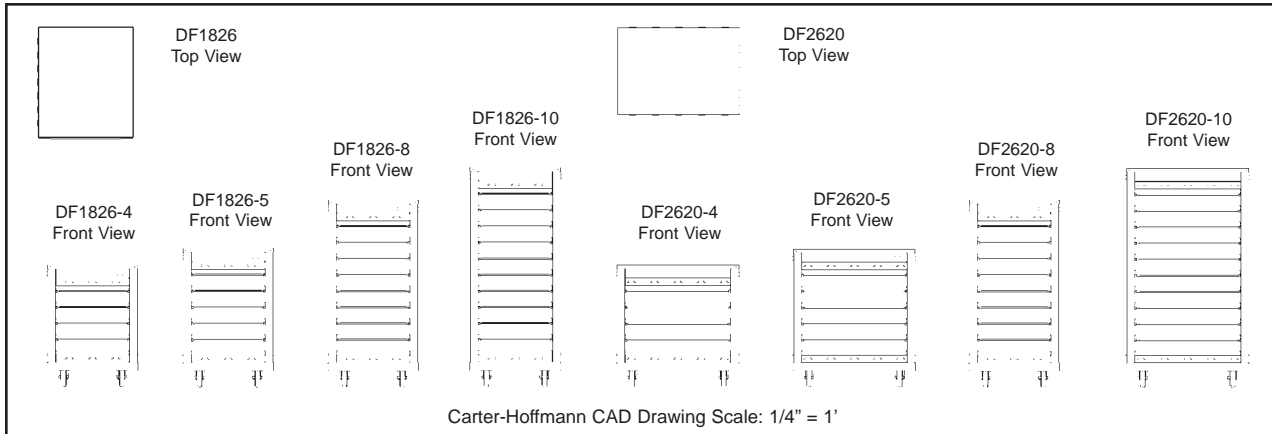

Model Number	Pan/Tray Capacity		Number of Shelves	Overall Dimensions						Caster Diameter		Shipping Weight	
	12"x20"	18"x26"		Height		Depth		Width		in	mm	lbs	kg
				in	mm	in	mm	in	mm				
<input type="checkbox"/> DF1826-4	8	4	4	29½	749	27½	699	23½	597	3	76	182	83
<input type="checkbox"/> DF1826-5	10	5	5	33½	851	27½	699	23½	597	3	76	269	122
<input type="checkbox"/> DF1826-8	16	8	8	47	1194	27½	699	23½	597	3	76	352	160
<input type="checkbox"/> DF1826-10	20	10	10	55	1397	27½	699	23½	597	3	76	414	188
<input type="checkbox"/> DF2620-4	8	4	4	29½	749	22½	572	32	813	3	76	192	87
<input type="checkbox"/> DF2620-5	10	5	5	33½	851	22½	572	32	813	3	76	287	130
<input type="checkbox"/> DF2620-8	16	8	8	47	1194	22½	572	32	813	3	76	376	171
<input type="checkbox"/> DF2620-10	20	10	10	55	1397	22½	572	32	813	3	76	442	200

"-4" and "-5" units are stackable

**CONSTRUCTION...** All stainless steel exterior with aluminum shelves and product lids; gusseted and riveted double wall construction.

**BASE FRAME...** Constructed of stainless steel. 12 gauge stainless steel base.

**STACKABILITY...** Four-shelf and five-shelf units are stackable, without the need for a stacking kit.

**CASTERS...** 3" diameter casters with rubber tread. All swivel casters, fitted with brakes.

**DOORLESS PASS-THROUGH**

**DESIGN...** Individually heated shelves accommodate steam table and sheet pans. Doorless, pass-through design allows access from front and back of unit.

**LIDS...** Fully integrated aluminum lids are removable. Lids in place seal in moisture in 12"x20"x2.5" steam table pans. Easy to remove and clean.

**CONTROLS...** Electronic temperature controls with countdown timer and audio/visual alarm. One control for units with four and five shelves. Two controls for units with eight and ten shelves. Control allows user to program temperature in one degree increments up to 225°F (108°C). Timer can be set for up to 9 hours, 59 minutes, in one minute increments. Countdown converts to seconds when less than one minute is left. On/off rocker switch.

**HEATING SYSTEM...** Individually heated shelves. One tubular element and black hard coat aluminum plate for each shelf. Top shelf has an additional top mounted heater.

**ELECTRICAL CHARACTERISTICS...**

MODEL	WATTS	VOLTS	AMPS	PLUG
DF1826-4	1500	120	12.5	5-20P
DF1826-5	1800	120	15.0	5-20P
DF1826-8	2700	208	13.9	L6-20P
DF1826-10	3300	208	15.9	L6-20P
DF2620-4	1500	120	12.5	5-20P
DF2620-5	1800	120	15.0	5-20P
DF2620-8	2700	208	13.9	L6-20P
DF2620-10	3300	208	15.9	L6-20P

Six foot cord with grounded plug

**PERFORMANCE...** Capable of heating to 225°F (108°C). Preheat to 160°F (71°C) in approximately 15-20 minutes.

**OPTIONS & ACCESSORIES...**

- shelves for 4" deep pans (volume orders only - Contact Factory)
- 230 volt operation

PATENT PENDING

Specifications subject to change through product improvement & innovation.



**CARTER-HOFFMANN**  
1551 McCormick Ave., Mundelein, IL 60060  
(847) 362-5500 • (800) 323-9793 • Fax (847) 367-8981  
[www.carter-hoffmann.com](http://www.carter-hoffmann.com)





## DF Series Doorless Holding Cabinets Universal Shelves

*Since 1947, Foodservice Equipment That Delivers!*

**DOORLESS PASS-THROUGH DESIGN...** Easy access to pans - no need to open and close doors. Ergonomic pass-through for two-sided access and easy transfer from kitchen to serving area - connect your kitchen to your serving line with ease. Improves kitchen traffic flow.

**UNIVERSAL HOLDING CAPABILITY...** Unique design allows for a variety of holding environments in a single cabinet. Hold moisture-sensitive covered foods and uncovered foods all in one cabinet. Individual shelves eliminate flavor transfer between held items.

**HEATING SYSTEM...** Individually heated shelves keep food warm via direct contact with food pans.

**STACKABILITY...** Four-shelf and five-shelf units are field stackable, without the need for a stacking kit. Base of one unit (with casters removed) can nest inside the top of another unit (with top cover removed) using same fasteners and holes from cover.



DF2620-10



**BUILT-IN LIDS...** Covers seal in moisture and keep moisture-sensitive food fresh. Removable without tools for uncovered holding and easy cleaning.

**USER-FRIENDLY DIGITAL CONTROLS...** Allows for full control of cabinet temperature for optimal food quality and holding time. Shelf temperatures and holding times can be independently controlled. Audible alarm signals end of hold cycle. One controller for 4 & 5 shelf units; two controls for 8 & 10 shelf units.



### HASSLE-FREE HOLDING...

- Door-free
- Water-free
- User-friendly controls

