



# DF2620-3SS

## Doorless Holding Cabinet

### universal shelves for 4" deep pans

CARTER-HOFFMANN  
**11** FOOD SERVICE EQUIPMENT  
 HEATED HOLDING CABINETS

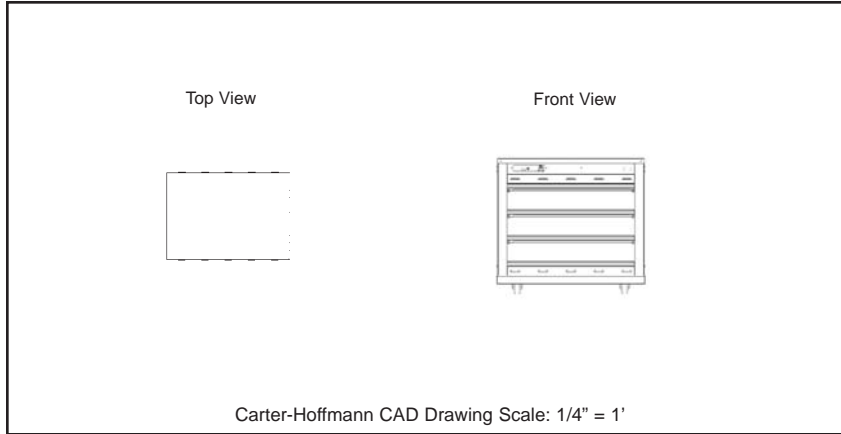

Model Number	Pan/Tray Capacity (up to 4" deep)		Number of Shelves	Overall Dimensions			Caster Diameter	Shipping Weight					
	12"x20"	18"x26"		Height*	Depth	Width							
<input type="checkbox"/> DF2620-3SS	6	3	3	in	mm	in	mm	in	mm	lbs	kg		
				29 1/8	740	22 5/8	575	32	813	3	76	195	88

Optional rolling stand adds 14-3/8" to height.

**CONSTRUCTION...** All stainless steel exterior with aluminum shelves and product lids; gusseted and riveted double wall construction.

**BASE FRAME...** Constructed of stainless steel. 12 gauge stainless steel base.

**STACKABILITY...** Units are stackable, without the need for a stacking kit.

**CASTERS...** 3" diameter casters with rubber tread. All swivel casters, fitted with brakes.

**DOORLESS PASS-THROUGH DESIGN...** Individually heated shelves accommodate steam table and sheet pans. Doorless, pass-through design allows access from front and back of unit.

**LIDS...** Fully integrated aluminum lids are removable. Lids in place seal in moisture in 12"x20"x4" steam table pans. Easy to remove and clean.

**CONTROLS...** Electronic temperature controls with countdown timer and audio/visual alarm. Control allows user to program temperature in one degree increments up to 225°F (108°C). Timer can be set for up to 9 hours, 59 minutes, in one minute increments. Countdown converts to seconds when less than one minute is left. On/off rocker switch.

**HEATING SYSTEM...** Individually heated shelves. One tubular element and black hard coat aluminum plate for each shelf. Top shelf has an additional top mounted heater.

**ELECTRICAL CHARACTERISTICS...** Operates on 120 volts, 1200 watts, 10 Amps, NEMA 5-15P. Six foot cord with grounded plug.

**PERFORMANCE...** Capable of heating to 225°F (108°C). Preheat to 160°F (71°C) in approximately 15-20 minutes.

**OPTIONS & ACCESSORIES...**

- 230 volt operation
- Rolling stand

# SPECIFICATIONS

PATENT PENDING

Specifications subject to change through product improvement & innovation.



**CARTER-HOFFMANN**  
 1551 McCormick Ave., Mundelein, IL 60060  
 (847) 362-5500 • (800) 323-9793 • Fax (847) 367-8981  
[www.carter-hoffmann.com](http://www.carter-hoffmann.com)



Printed in U.S.A. E94 0512  
 Carter-Hoffmann is a trademark  
 of Carter-Hoffmann LLC.

# FEATURES & BENEFITS

1551 McCormick Avenue, Mundelein, Illinois 60060  
Tel. (847)362-5500 • (800)323-9793 • Fax (847)367-8981  
www.carter-hoffmann.com



## DF2620-3SS Doorless Holding Cabinet universal shelves for 4" deep pans

*Since 1947, Foodservice Equipment That Delivers!*

**DOORLESS PASS-THROUGH DESIGN...** Easy access to pans - no need to open and close doors. Ergonomic pass-through for two-sided access and easy transfer from kitchen to serving area - connect your kitchen to your serving line with ease. Improves kitchen traffic flow.

**UNIVERSAL HOLDING CAPABILITY...** Unique design allows for a variety of holding environments in a single cabinet. Hold moisture-sensitive covered foods and uncovered foods all in one cabinet. Individual shelves eliminate flavor transfer between held items.

**HEATING SYSTEM...** Individually heated shelves keep food warm via direct contact with food pans.



**BUILT-IN LIDS...** Covers seal in moisture and keep moisture-sensitive food fresh. Removable without tools for uncovered holding and easy cleaning.



**USER-FRIENDLY DIGITAL CONTROLS...** Allows for full control of cabinet temperature for optimal food quality and holding time. Shelf temperatures and holding times can be independently controlled. Audible alarm signals end of hold cycle

### HASSLE-FREE HOLDING...

Door-free  
Water-free  
User-friendly controls

