

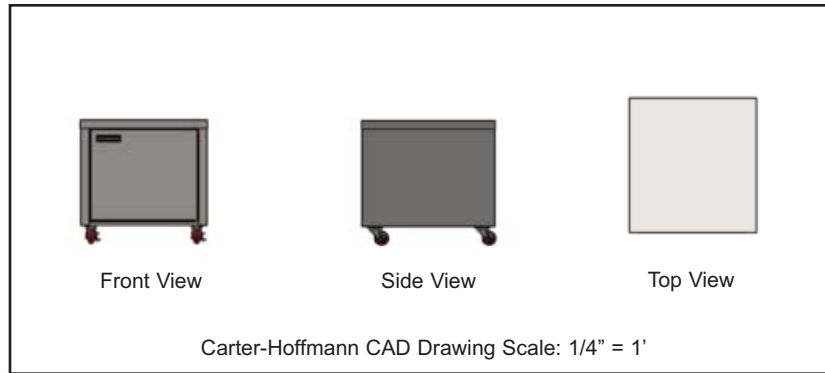

## FST2828 FRY STATION TABLE

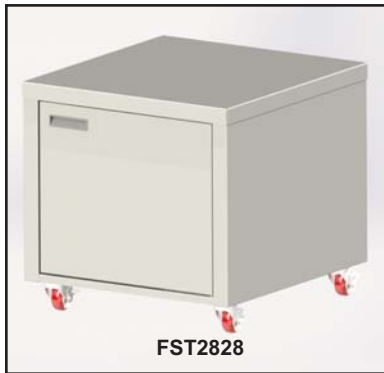

Model Number	Counter-top Dimensions	Overall Dimensions						Caster Diameter		Shipping Weight	
		Height		Depth		Width		in	mm	lbs	kg
		in	mm	in	mm	in	mm				
□ FST3028	28 <sup>1</sup> / <sub>8</sub> x 28 <sup>1</sup> / <sub>8</sub> (714mm x 714mm)	27 <sup>3</sup> / <sub>4</sub>	705	28 <sup>1</sup> / <sub>8</sub>	714	28 <sup>1</sup> / <sub>8</sub>	714	3	76	92	41

**CONSTRUCTION...**All welded stainless steel construction. All horizontal supports are welded and polished to vertical uprights to form one-piece rigid frame. Extra welds on bottom supports for maximum support and added durability. Counter sized to fit one CNH28LP Crisp 'N Hold fry station (not included).

**MATERIAL...**All stainless steel construction; Framework and supports constructed of 1.5" x 18 gauge seamless, polished stainless steel tubing. 1.5" stainless steel tubular frame. 16 gauge single panel top and bottom. 18 gauge side panels. 14 gauge stainless steel caster bolsters.

**DOORS...** Pocket style doors; 18 gauge exterior and 20 gauge interior. Recessed finger pulls and magnetic catch. Dual-sided access.

**CASTERS...** 3" diameter red Performa casters. Plate mounted and bolted to base. All full ball bearing swivel. Two fitted with brakes.

**UNDER-COUNTER STORAGE...**Undercounter storage area.

Specifications subject to change through product improvement & innovation.

**CARTER-HOFFMANN**  
1551 McCormick Ave., Mundelein, IL 60060  
(847) 362-5500 • (800) 323-9793 • Fax (847) 367-8981  
[www.carter-hoffmann.com](http://www.carter-hoffmann.com)