

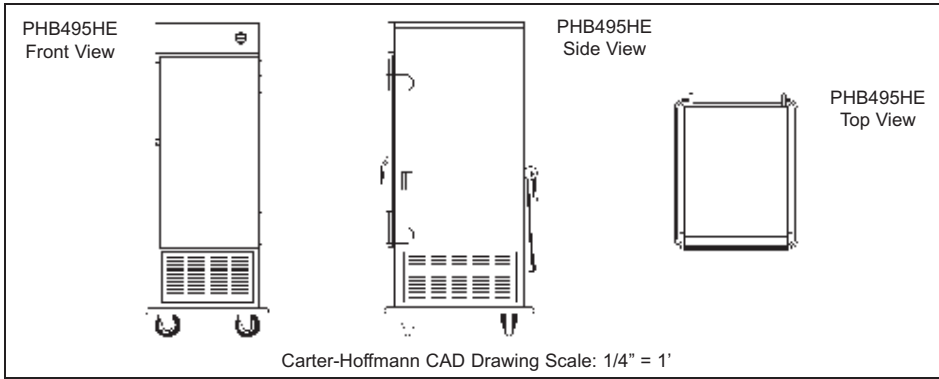

# PHB495HE AIR-SCREEN TRAYLINE REFRIGERATOR

CARTER-HOFFMANN  
11  
MOBILE REFRIGERATORS  
FOOD SERVICE EQUIPMENT



Model Number	Pan/Tray Capacity		Slide Pairs Standard	Inside Working Height		Overall Dimensions			Caster Diameter		Shipping Weight				
	14" x 18"	18" x 26"		in	mm	Height in mm	Depth in mm	Width in mm	in	mm	lbs	kgs			
PHB495HE	30	15	15	45 <sup>3</sup> / <sub>4</sub>	1162	80	2032	39 <sup>7</sup> / <sub>8</sub>	1013	31 <sup>1</sup> / <sub>2</sub>	800	6	152	541	226

**CONSTRUCTION...** Completely welded cabinet construction with outer cabinet formed and welded to base. All seams turned in to eliminate raw edges.

**CABINET MATERIAL...** All stainless steel construction; 20 gauge polished exterior and 24 gauge interior.

**BASE FRAME...** 14 gauge aluminized steel full depth caster bolsters with 1" x 1" 14 gauge aluminized steel tubes welded to bolsters.

**CASTERS...** 6" diameter, all swivel, performa rubber tread. Sealed roller bearing swivel. Zerk grease fittings. Plate mounted and bolted to base in offset, wheel-ahead pattern. Two casters fitted with brakes.

**BUMPER...** Non-marking gray vinyl bumper set in heavy-duty 1/8" thick extruded aluminum frame with reinforced corner cutouts.

**INSULATION...** Combination foam and high density fiberglass continuous wrap-around insulation.

**STYLING...** All stainless steel with glass door.

**DOOR...** Tempered glass door set in extruded aluminum frame. Positive action door hold up device keeps door open and in place for easy loading and unloading. Field reversible.

**HINGES...** Welded on, stainless steel 12 gauge butt type hinges with 3/8" fixed pin. 270 degree door swing. Field-reversible.

**PUSH HANDLE...** 1" diameter stainless steel tubular push handle bolted to rear of cabinet. Extends full width of cabinet. Equipped with donut bumpers on each end.

**LATCH...** Heavy-duty edgemount latch with magnetic catch.

**CONTROLLER...** Digital display controller set flush with control panel. Displays set point and operating temperature.

**TRAY RACK ASSEMBLIES...** Heavy-duty 18 gauge stainless steel angle slides fixed at 3" spacing. "No-tip" feature to facilitate partial pull-out of pans for easy access to contents. Partial pull-out of a pan will not "break" air screen.

**ON/OFF SWITCH...** Toggle style with guard.

**REFRIGERATION SYSTEM...** Self-contained high-efficiency, evaporator coil refrigeration system. Components include 1/2 h.p. air cooled high torque condensing unit, horizontal air screen, 1/2 ton expansion valve, filter/dehydrator and large capacity electrical condensate evaporator. Refrigerant charge of approx. 30 oz. CFC-free R134a.

**DEFROST...** Automatic and manual hot gas bypass defrost. Manual defrost button located on controller.

**ELECTRICAL CHARACTERISTICS...** Operates on 120 volts, 60 cycle, single phase, 11.0 running amps. Ten foot 3-wire rubber cord with 3 prong grounding plug. NEMA 5-20P.

**PERFORMANCE...** Capable of cooling cabinet to 35°F to 40°F. Approximate pull down time to 40°F - 30 minutes. Air curtain capable of maintaining 40°F internal air temperature for two hours with door open.

**ACCESSORIES/OPTIONS...**

- Rack hold down device
- Locking door latches
- Controller programmed for °C scale

# SPECIFICATIONS

Meets DOE energy regulation requirement: 10 CFR 431 Subpart C-Commercial Refrigerators, Freezers and Refrigerator-Freezers Standard

Specifications subject to change through product improvement & innovation.

**CARTER-HOFFMANN**

1551 McCormick Ave., Mundelein, IL 60060  
(847) 362-5500 • (800) 323-9793 • Fax (847) 367-8981  
[www.carter-hoffmann.com](http://www.carter-hoffmann.com)



Printed in U.S.A. G20 1115  
Carter-Hoffmann is a trademark of Carter-Hoffmann, LLC

# FEATURES & BENEFITS

## PHB495HE

### AIR SCREEN TRAYLINE REFRIGERATOR

*Since 1947, foodservice equipment that delivers!*

**COMPLETELY WELDED TURNED-IN SEAM CONSTRUCTION...** All stainless steel construction. Adds rigidity to entire cabinet for maximum durability and reliable performance, and eliminates raw edges for easy cleaning and safety.

**HIGH EFFICIENCY REFRIGERATION SYSTEM WITH ENVIRONMENTALLY SAFE COOLANT...** Highly efficient energy management refrigeration system provides faster pull down and recovery times. Combination foam and high-density fiberglass insulation in 2" thick walls.

**PERFORMA RUBBER TREAD CASTERS WITH SEALED ROLLER BEARING...** Long lasting, easy rolling for maximum load and minimum maintenance.



**DIGITAL READ-OUT CONTROLLER...** For fast, accurate temperature readings with no calibration.

**270 DEGREE DOOR SWING WITH DOOR HOLD OPEN DEVICE...** Door swings out of the way and is held securely in place for easy loading and unloading. Field-reversible hinges.

**HEAVY-DUTY STAINLESS STEEL BASE FRAME...** 12 gauge caster boosters with tubular perimeter frame to withstand heavy loads and harsh transport conditions.

**NON-MARKING BUMPER SET IN HEAVY-DUTY 1/8" THICK EXTRUDED ALUMINUM FRAME...** Protects doorways, walls and cart from damage.

**OFFSET "WHEEL AHEAD" PATTERN...** Only one wheel can pass over uneven surfaces at a time for easy handling and steering.

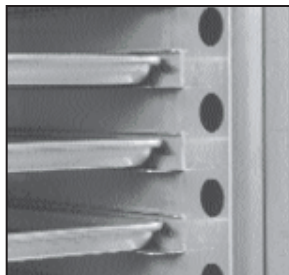

**"NO TIP" TRAY SLIDES...** Trays cannot tip - even when pulled out half way. Enable easier access to contents of cabinet without affecting air screen.

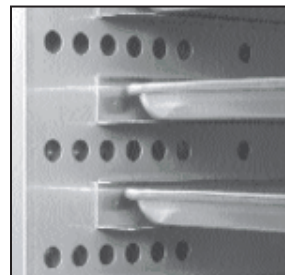

**DUAL FAN HORIZONTAL AIR SCREEN...** Designed to maintain lower interior cabinet temperature. Pan pulled out part way will not affect air screen.

1551 McCormick Avenue, Mundelein, Illinois 60060  
Tel. (847)362-5500 • (800)323-9793 • Fax (847)367-8981  
[www.carter-hoffmann.com](http://www.carter-hoffmann.com)

