

# OUTDOOR FRYERS

## PF-1, 2

Project: \_\_\_\_\_  
Item #: \_\_\_\_\_  
Quantity: \_\_\_\_\_



Bring all the functionality of your indoor kitchen outdoors with a compact and sturdy Crown Verity mobile fryer. Our Pro fryers are designed to cook high volumes of product in a short period of time. The fryers are for outdoor use only. With 14" wheels, they are easy to move, making them ideal for caterers, party rentals and special events.

Our single - well model is perfect for smaller applications and spaces. Competely mobile, you can bring frying performance wherever you need it.

If frying is big on your menu, you need our double - well model. Optional side shelves and pan adapters offer maximum functionality.

One 30 Lb. propane tank will give you approximately 10 - 12 hours of frying time - even longer if the thermostat is set at lower limits. Each fry tank has a 35 - 40 Lb. oil capacity and will cook between 60 and 65 Lbs. of frozen fries per hour.

### SPECIFICATIONS

- Stainless steel cabinet, fry tanks(s)
- Two 14" wheels and two total lock casters
- Two fry baskets per tank with plastic coated handles
- Three heat exchanger tubes per tank positioned for easy cleaning
- Tank holder(s) to hold 30 Lb. vertical propane tank(s)
- Stainless steel tank cover(s)
- Two stage regulator(s) and hose(s) on LP models
- Ships fully assembled on a skid
- 1.25" full port ball type drain valve with drain pipe extension
- c ETL us, Conforms to ANSI Z83.11/CSA 1.8

### More Standard Features

- 90,000 BTU/hour input per tank
- High limit shut off safely shuts off gas flow if fryer temperature exceeds high limit
- Millivolt thermostat control adjusts from 200 - 400 °F
- Combination gas shut-off valve and pilot ignition system
- 1 year parts and labor limited warranty. Stainless steel fry tank will be warranted for 1 year. If tank is found to have a leak and is verified by an authorized service agency, the fry tank only will be replaced. Replacement fryer tank will be warranted for the balance of the original warranty.

### Options/Accessories

- Dump station (incl. 4" deep pan and 2.5" perforated pan)
- End Shelf
- Propane tanks (30 Lb.)

### Certifications



**SPECIFICATIONS**



Model	PF-1	PF-2
Thermostat	200° to 400° F	200° to 400° F
BTUH	90,000	90,000 per tank
Actual Weight (lbs)	180	301
Shipping Weight (lbs)	240	375
Capacity	35 - 40 Lb. per tank	35 - 40 Lb. per tank
Cabinet Length	29.75"	44.75"
Overall Dimensions	38" W x 30.5" D x 48.75" H	53" W x 30.5" D x 48.75" H

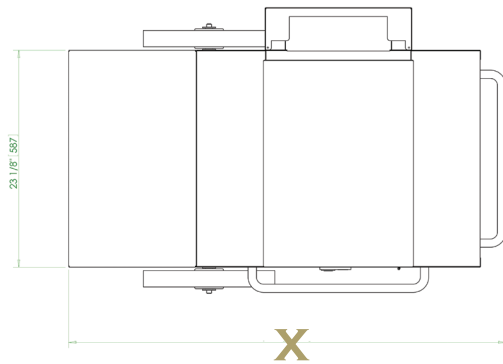

PF	"X"
1	38"
2	53"

