



MF90 Portable 80 and 110-lb Capacity Oil Filters

Project _____
 Item _____
 Quantity _____
 CSI Section 11400 _____
 Approval _____
 Date _____

MF90 Portable 80 and 110-lb. Capacity Oil Filters

Models

MF90/80

MF90/80LP

MF90/110



MF90/80LP
Micro-Flo Portable Oil Filter



MF90/80
Micro-Flo Portable Oil Filter

Standard Features

- 80-lb (40 liter) or 110-lb (55 liter) oil capacities
- 4 GPM pump, 1/3 H.P. heavy-duty motor
- 5' (152.4 cm) return hose
- Cover with opening for return hose
- Durable stainless-steel pan and pump housing
- Heavy-duty casters with welded construction
- Filter starter kit
- LP model is low profile, fitting under most fryer drains

Options & Accessories

- See Dean Price List for filter supplies and optional filtering accessories

Specifications

Designed to make daily filtration easy, quick and efficient

Dean's large-capacity, heavy-duty MF portable filters are designed to support routine oil filtration which preserves oil life and maintains consistent fried food quality. Crumbs, sediment, and by-products created by high-heat frying take a toll on oil life unless a daily system of filtration and frypot cleaning is in place.

The filters' powerful 4 GPM, 1/3 H.P. heavy-duty pump circulates the used oil through the filter media to trap the crumbs, sediment, and by-products that compromise flavor profiles and reduce useful oil life. The pump then returns the clean filtered oil back to the frypot. Cleanup is easy, simply remove the filter media.

The 5' hose returns filtered oil with ease, amply reaching the frypot to wash crumbs from the walls and the bottom of the frypot. The quick disconnect feature on the hose allows for compact storage and easy cleaning.

All models have a reversible pump so used oil can be pumped from and filtered oil can be returned to the frypot.

Available in both 80-lb (40 liter) and 100-lb (55 liter) capacities. All MF filters fit under the drain of all Dean fryers. The lower pan height of the MF90/80LP model (9-5/8"), allows it to fit under the drain of most fryers.





MF90 Portable 80 and 110-lb. Capacity Oil Filters

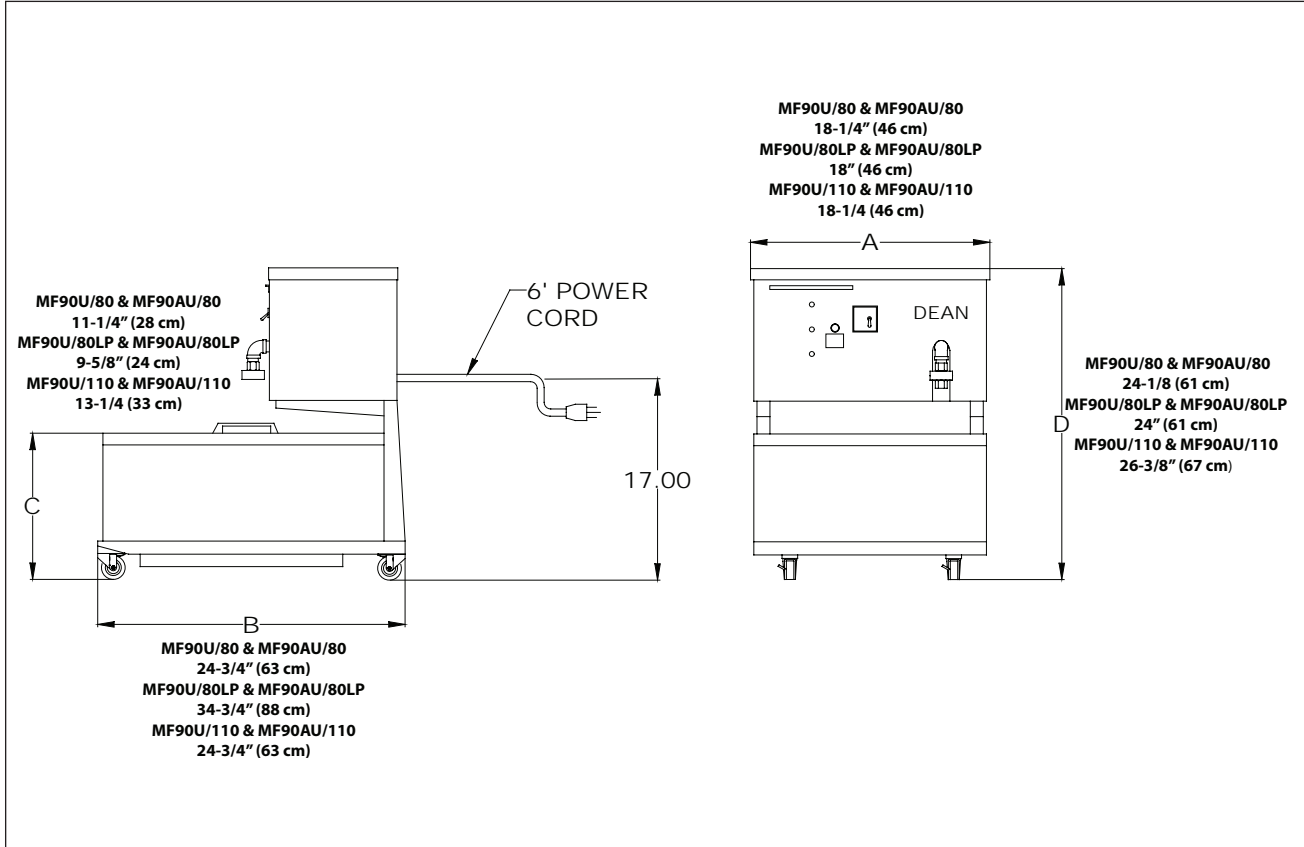

DIMENSIONS

MODEL NO.	OIL CAPACITY	OVERALL SIZE (cm)				SHIPPING INFORMATION					
		A WIDTH	B DEPTH	C TANK HEIGHT	D OVERALL HEIGHT	WEIGHT	CLASS	CU.FT.	DIMENSIONS (cm)		
									WIDTH	DEPTH	HEIGHT
MF90/80	80 lb. (40 liter)	18-1/4" (46)	24-3/4" (63)	11-1/4" (28)	24-1/8" (61)	120 (54.4 kg)	85	18	24" (60.9)	39-3/4" (100.9)	33" (83.8)
MF90/80LP	80 lb. (40 liter)	18" (46)	34-3/4" (88)	9-5/8" (24)	24" (61)	147 (67.0)	85	18	24" (60.9)	39-3/4" (100.9)	33" (83.8)
MF90/110	110 lb. (55 liter)	18-1/4" (46)	24-3/4" (63)	13-1/4" (33)	26-3/8" (67)	125 (57.0 kg)	85	18	24" (60.9)	39-3/4" (100.9)	33" (83.8)

POWER REQUIREMENTS

All Models: 120V/60 Hz 1 Ph 6.2 A

ORDERING DATA

Please specify:
Model number

HOW TO SPECIFY

The following description will assist with ordering the features desired for this equipment:

- MF90/80 80-lb. (40 liter) oil capacity portable oil filter with reversible pump
- MJ90/80LP 80-lb. (40 liter) oil capacity low profile portable oil filter with reversible pump
- MF90/110 110-lb (55 liter) oil capacity portable oil filter with reversible pump

Model # _____
CSI Section 11400

8700 Line Avenue
Shreveport, LA 71106
USA

Tel: 318-865-1711
Tel: 1-800-221-4583
Fax: 318-868-5987

E-mail: info@frymaster.com

www.frymaster.com

Bulletin No. 830-0047

Revised 11/2/15

Litho in U.S.A. ©Frymaster



We reserve the right to change specifications appearing in this bulletin without incurring any obligation for equipment previously or subsequently sold. Check www.frymaster.com for updates.