



402P

Self-Contained Compact Work Top Refrigerator

Project _____
 Item _____
 Quantity _____
 CSI Section 11400
 Approved _____
 Date _____

402P: Self-Contained Compact Work Top Refrigerator

Models

- 402P Single section refrigerator



402P

Standard Features

- Features Delfield's exclusive ABS interior. ABS is extremely durable - it won't dent, chip or corrode and is backed by a limited lifetime warranty
- Stainless steel front, sides and top
- Two epoxy coated wire shelves, standard installed per unit
- Environmentally friendly R290 refrigerant
- Foamed in place environmentally friendly, Kyoto Protocol Compliant, Non ODP (Ozone Depletion Potential), Non GWP (Global Warming Potential) polyurethane cuts energy costs
- Black recessed quick grip handle
- Rugged 6" high heavy duty metal legs
- Door hinging available on either right or left, right side is standard
- 60-cycle single phase electrical system
- 6' cord and plug supplied
- Three year parts and labor warranty and an additional two year compressor parts warranty

Options & Accessories

- Stainless steel back
- Plastic laminate on front
- Additional wire shelves
- Stainless steel single-tier overshef
- 3" (8cm) diameter casters
- 5" (12.7 cm) diameter casters
- Door lock (original order only; not field installable; per door)
- Full-size composite-type cutting top

Specifications

Exterior bottom shall be heavy-gauge galvanized metal. Exterior ends shall be heavy-gauge stainless steel.

Exterior top: One-piece, 22-gauge stainless steel with front edge turned down to form nosing and rear edge turned up to form a 2" (5.1 cm) thick by 4" (10.2 cm) high backsplash.

Base interior: One-piece thermoformed ABS plastic material, with integral shelf supports. Base shall be fully insulated with high-density foamed-in-place environmentally friendly, Kyoto Protocol Compliant, Non ODP (Ozone Depletion Potential), Non GWP (Global Warming Potential) polyurethane.

Door shall have a heavy-gauge stainless steel exterior, with a thermoformed ABS plastic interior liner, and shall be fully insulated with foamed-in-place polyurethane. Door handles shall be black, recessed ABS. Cabinet shall have (2) adjustable epoxy-coated wire shelves installed.

Equipment shall be mounted on 6" (15.2 cm) high metal legs with black enamel finish.

Electrical Connections: 115 volt, 60 Hertz, single phase. Unit shall have a 6' (1.8 m) long electrical cord and NEMA 5-15P plug. Cord and plug shall be located on the rear of the cabinet 16" (40.6cm) above floor, 5" from left side.

Refrigeration system shall use R290 refrigerant. Compressor shall be 1/5 h.p., with condenser coil and hot gas condensate evaporator mounted on rear of cabinet. Evaporator coil shall be mounted on the interior rear wall of the cabinet. Temperature control is mounted to the exterior rear of the cabinet. Refrigerant flow shall be controlled by a capillary tube. Cabinet shall maintain 36°F to 40°F (2°C to 4°C) interior cabinet temperature.

System is controlled using Delfield's ACT-Advanced Control Technology electronic temperature control, which provides improved pull down times, reduces compressor cycling and longer compressor life with lower energy consumption.

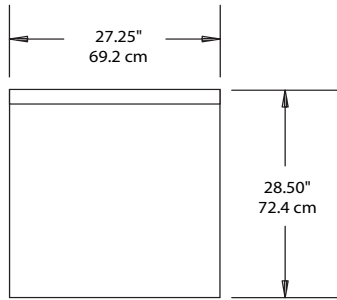
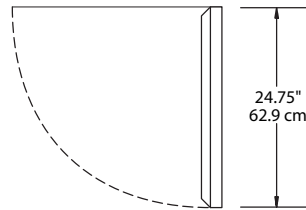

 Plan View
402P

Standard door hinging is on right
Hinging may be reversed
But a new door is required

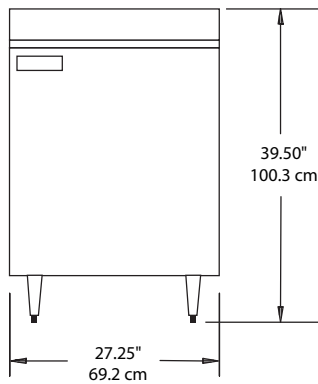
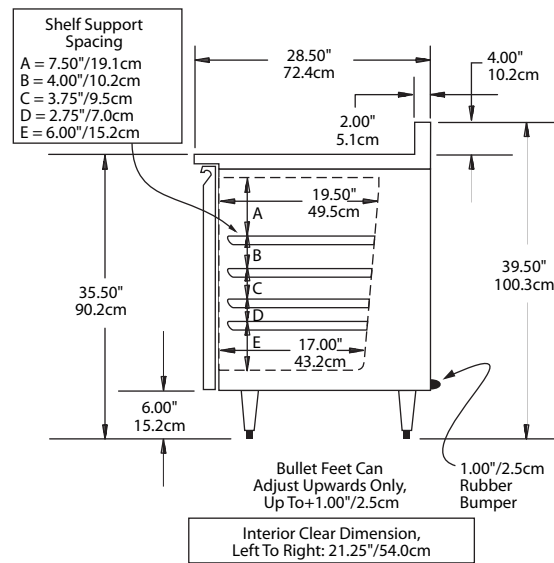
 Door Clearance Detail
402P

 Elevation View
402P

 Right End View
402P

INSTALLATION NOTE:

Refrigeration system is designed so that air will flow under the unit, through the compressor area and out the top rear of the unit. Any restriction to this air flow path will void the warranties.

Specifications

Model	# of Shelves	Shelf Area	Volume	H.P.	V/Hz/Ph	Amps	Nema Plug	Ship Weight	Energy (KWH/Day)
402P	2	4.6ft ²	5.7ft ³	1/5	115/60/1	4.0	5-15P	176lbs (80kg)	1.16

Delfield reserves the right to make changes to the design or specifications without prior notice.