

“L” SHAPED HOT FOOD COUNTER

DineXpress

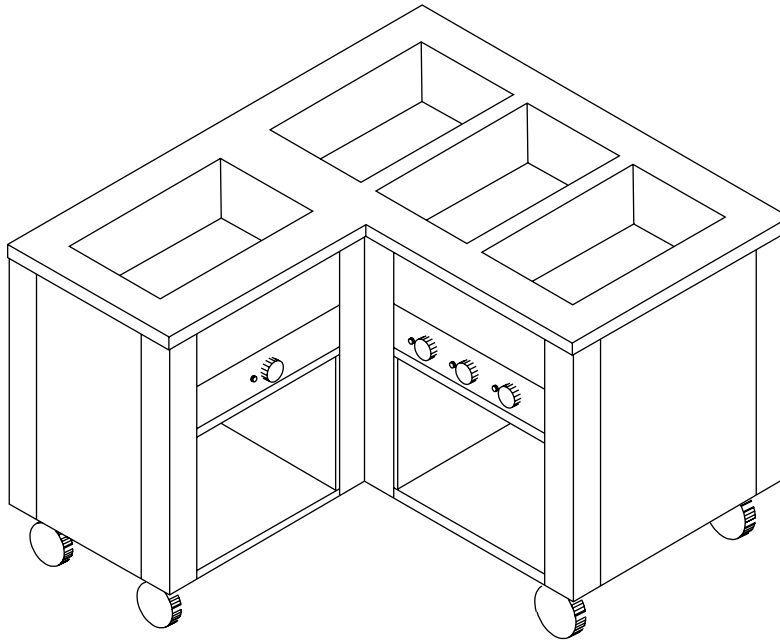

Item Number: DXDHF/4LL

Item Numbers

- DXDHF3LL
- DXDHF3LR
- DXDHF4LL
- DXDHF4LR
- DXDHF5LL
- DXDHF5LR

Application

The “L” shape counter provides easy access to both the hot food and the tray line.

Construction

General: The DineXpress “L” Shape Hot Food Counter shall have a 16-gauge 300 series stainless steel top with 1-1/2” turn down on all sides. Front and end panels shall be of 20-gauge stainless steel. The corner posts shall be 14-gauge stainless steel.

Heated wells: Individual wells are deep drawn stainless steel 12” x 20” x 6.5” deep with covered corners. Each well is thermostatically controlled with temperature adjustment knobs. A signal light indicates temperature cycling for each well.

Wells are insulated with high density fiberglass. An additional non-conductive heat barrier is also provided to seal and isolate heat wells from top surface.

Casters: The DineXpress “L” Shape Hot Food Counters are provided with 5-5” diameter, heavy duty non-marking swivel casters, 2 are fitted with brakes.

Heating System: Each well is heated by means of a 240v/1200 watt or 208v/1000 watt heating system. The DineXpress Hot Food Counters are equipped with easy to service slide out heating elements. Each unit is provided with a 10’ cord and plug.

Options

- Manifold drains
- Food protector guards
- Drop down work shelf
- Duplex outlet
- Overhead shelf
- Legs in lieu of casters

Warranty

One year parts and labor.

DINEX[®]

Building 2, Suite 106
628 Hebron Avenue
Glastonbury, CT 06033
800.523.9752 Fax: 860.652.3135
www.dinex.com

"L" SHAPED HOT FOOD COUNTER

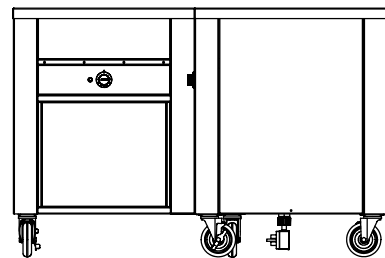
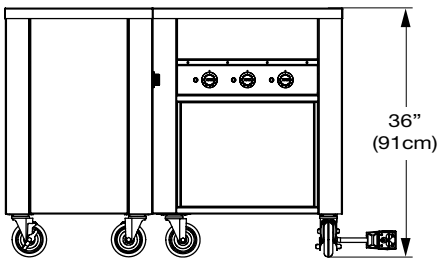
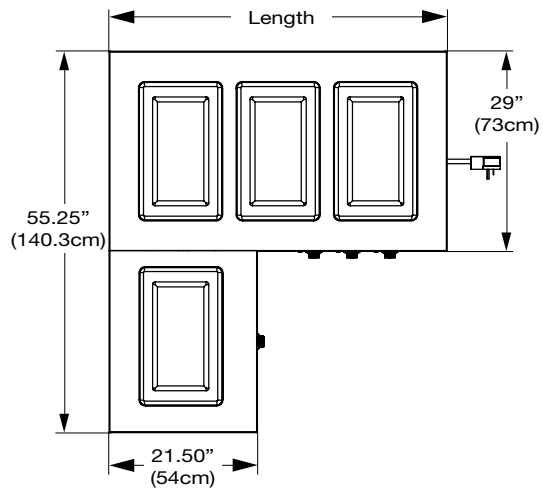

Items and Dimensions

ITEM NUMBER	MODEL NUMBER	LENGTH	WATTS		AMPS		SHIP WEIGHT	SHIP CUBE	NEMA NUMBERS	
			240v	208v	240v	208v			240v	208v
DXDHF3LL	DHF/3LL	35" (88.9cm)	3600	3000	15	14.4	410 lb. (186.1kg)	24.1	6-20P	6-20P
DXDHF3LR	DHF/3LR	35" (88.9cm)	3600	3000	15	14.4	410 lb. (186.1kg)	23.6	6-20P	6-20P
DXDHF4LL	DHF/4LL	49" (124.5cm)	4800	4000	20	19.2	420 lb. (190.7kg)	24.1	6-30P	6-30P
DXDHF4LR	DHF/4LR	49" (124.5cm)	4800	4000	20	19.2	420 lb. (190.7kg)	29.9	6-30P	6-30P
DXDHF5LL	DHF/5LL	63" (160cm)	6000	5000	25	24.0	460 lb. (208.8kg)	24.1	6-50P	6-50P
DXDHF5LR	DHF/5LR	63" (160cm)	6000	5000	25	24.0	460 lb. (208.8kg)	36.2	6-50P	6-50P

Note: Electrical specifications are for the base model only and subject to change pending options specified.



Please confirm that you have the most current specification sheet by visiting www.dinex.com.
Dinex® reserves the right to change specifications and product design without notice.
Such revisions do not entitle the buyer to corresponding changes, improvements, additions or replacements for previously purchased equipment.



Building 2, Suite 106
628 Hebron Avenue
Glastonbury, CT 06033
800.523.9752 Fax: 860.652.3135
www.dinex.com