

CONVECTION HEATED PLATE DISPENSERS



Item Numbers

- DXIDPC20120
- DXIDPC30180



Application

The Convection Heated Plate Dispenser is designed for heating china plates (up to 10-1/4" in diameter). It's ideal for super heating plates in conjunction with the Dinex Induction Heating System.

Construction

The exterior is constructed of 18-gauge 300 stainless steel. The inner wall of the cabinet is constructed of .063 high strength aluminum. All sides and top of cabinet are insulated with superior rated insulation for heat retention and energy efficiency. The cabinet is mounted on four 3½" exclusive Dinex Performa swivel casters (two with brakes) with non-marking cushion tread wheel.

Heating System

The heating system is thermostatically controlled, using forced air to heat each cabinet for a combined 3200 watts (2 silo) and 4800 watts (3 silo). The compartment has a temperature range of 140°F to 330°F (60°C to 166°C) and is programmable. Unit is 208 Volt, 60 Hz, 1 Phase and features a 10' long 20 AMP power cord and NEMA 6-20P plug (2 silo) or NEMA 6-30P plug (3 silo).

Dispenser

Self-Leveling dispenser mechanisms are constructed of 304 stainless steel featuring springs that are isolated to protect from excessive and prolonged heat and therefore premature stretching. Springs are field adjustable without tools to accommodate a wide variety of plates. Each silo accommodates plate sizes 7.5" (19 cm) to 10.25" (26 cm) in diameter and is factory set for the Dinex 9" plate.

Programmability

A simple controller allows one to adjust the cavity temperatures from 140°F to 330°F (60°C to 166°C). It is factory preset for 210°F (99°C) for the first 90 minutes, then drops to 180°F (82°C).

Capacity

- Each plate silo holds the large capacity of 75 Dinex 9" plates.

Maintenance/Safety

Features latchless hinged lids for maximum convenience. Safety open lid catch prevents accidental lid closure. Casters have sealed bearings for low maintenance and increased maneuverability. Springs are certified and specially tempered to minimize spring adjustments over time. Units feature a 10' cord and cord wrap for layout changes and flexibility. Silos are removable and springs are adjustable without tools.

Warranty

One year parts and labor.

We do not accept returns on any Dinex equipment or Dinex custom products. Please contact your local Dinex rep to ensure order accuracy prior to ordering.

CONVECTION HEATED PLATE DISPENSERS

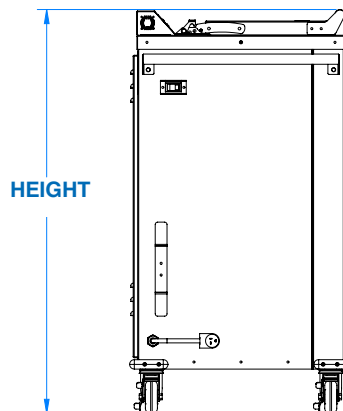
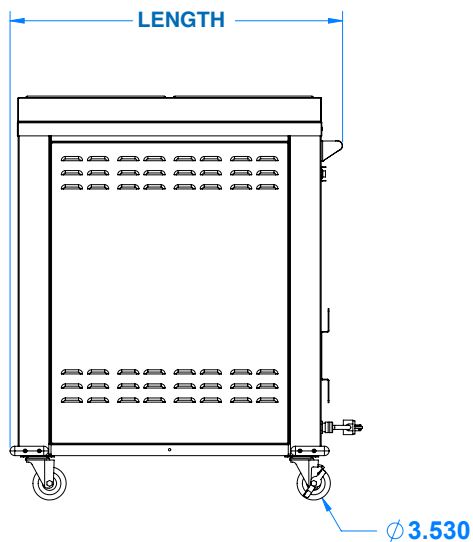

TOP VIEW

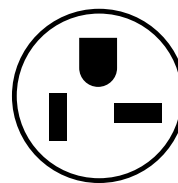
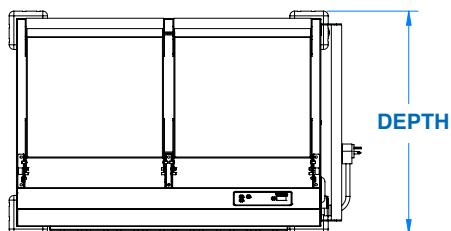

Nema 6-20P

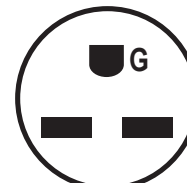

Nema 6-30P

Items and Dimensions

ITEM NUMBER	MODEL NUMBER	LENGTH	DEPTH	HEIGHT	CASTERS		ELECTRICAL SPECIFICATIONS			SHIP WEIGHT	SHIP CUBE	NEMA PLUG
					TYPE	DIA.	WATT	AMP.	VOLTS			
DXIDPC20120	IDPC20120	35.36" (89.8 cm)	23.68" (60.1 cm)	42.96" (109.2 cm)	4 Swivel 2 w/brake	3 ½"	3200	15.4	208 60 HZ	260 lb (117.9 kg)	21.9	6-20P
DXIDPC30180	IDPC30180	45.00" (114.3 cm)	23.68" (60.1 cm)	42.96" (109.2 cm)	4 Swivel 2 w/brake	3 ½"	4800	23.1	208 60 HZ	320 lb (145 kg)	28.4	6-30P

DINEX
A CARLISLE COMPANY

4711 E Hefner Road
Oklahoma City, OK 73131
800.654.8210 • 405.475.5600
www.dinex.com

Please confirm that you have the most current specification sheet by visiting www.dinex.com.
Dinex® reserves the right to change specifications and product design without notice.
Such revisions do not entitle the buyer to corresponding changes, improvements, additions or replacements for previously purchased equipment.