

## STARTER STATION



### Item Numbers

- DXTMPSTARTER

### Application

The Starter Station improves tray line efficiency and meal delivery. This versatile unit is designed to roll net to, or to cantilever over the patient tray assembly line to provide an efficient method of storing and dispensing condiments and flatware onto patient trays.

Durable, plastic bins hook onto the lower frame to hold and dispense condiments. A solid upper shelf holds other tray line materials such as tray covers, napkins or additional plastic bins. Shipped with bins and bin dividers available.

### Construction

**Frame:** 16-gauge stainless steel, 1"sq.

**Top Shelf:** 18-gauge stainless steel

**Bottom Shelf:** Supports 5 plastic bins (shipped standard with each unit)

**Casters:** 5" swivel casters; two have locking brakes.

### Features

- Cantilever design brings contents within easy reach for convenient tray preparation.
- Bins with dividers (optional) accommodate different types and quantities of tray items.
- 5" swivel casters with locking brakes allow smooth and stable positioning of the station.
- Stainless steel construction is attractive and rugged.

### Warranty

One year parts and labor.

# DINEX<sup>®</sup>

Building 2, Suite 106  
628 Hebron Avenue  
Glastonbury, CT 06033  
800.523.9752 Fax: 860.652.3135  
www.dinex.com

# STARTER STATION

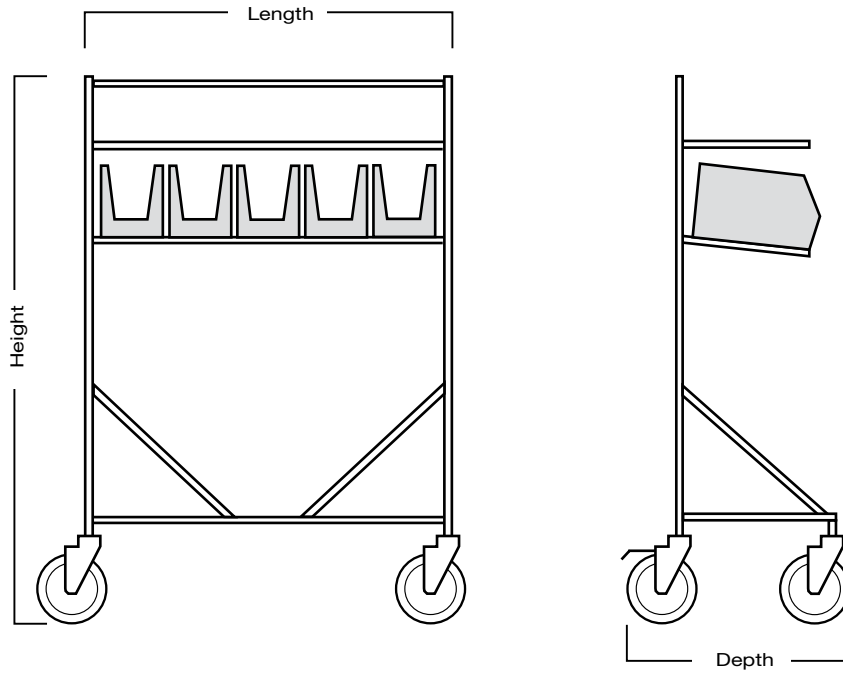

## Items and Dimensions

ITEM NUMBER	MODEL NUMBER	LENGTH	DEPTH	HEIGHT	SHIP WEIGHT	SHIP CUBE
DXTMPSTARTER	TMPSTARTER	46" (117cm)	21" (53cm)	60.75" (154cm)	245 lb. (111kg)	36.5

## Optional Accessories

ITEM NUMBER	MODEL NUMBER	DESCRIPTION
DXTMP30-176	TMP30-176	Plastic bin (14.75' x 8.25" x 7")
TMP30-240	TMP30-240	Plastic bin divider



Please confirm that you have the most current specification sheet by visiting [www.dinex.com](http://www.dinex.com).  
 Dinex® reserves the right to change specifications and product design without notice.  
 Such revisions do not entitle the buyer to corresponding changes, improvements, additions or replacements for previously purchased equipment.

# DINEX®

Building 2, Suite 106  
 628 Hebron Avenue  
 Glastonbury, CT 06033  
 800.523.9752 Fax: 860.652.3135  
[www.dinex.com](http://www.dinex.com)