

TORTILLAPRO

Worlds Best Tortilla Press

DP2000BP Dual Heat Manual Tortilla Press



Now you can flatten flour tortilla dough like a pro with one easy motion!

Whether you need to simply par bake your dough, or speed up the flattening operation, the Model DP2000 does it all. Mushi skins, pizzas (especially thin crust) can all be flattened faster than any other method used today.

Each platen contains an independent heating system designed exclusively by ProLuxe. The patented technology is backed by the ProLuxe limited lifetime warranty, and has separate controls that provide a temperature range of 100 – 450F. This allows you to adjust exactly the right temperature for each side of the product from a thick tortillas to a paper-thin mushi skin.

If you are using this unit for pizzas please order with Teflon platens.

Features

- Operation is entirely manual.
- Produces par-baked tortillas in seconds.
- Compact size fits just about anywhere.
- Safe to operate and clean.
- Patented embedded heating element is backed by the exclusive ProLuxe limited lifetime warranty.

In addition to the quality execution and unique customization capabilities, our expert technical support team supports the ProLuxe DP2000. We are available 24 hours a day/7 days a week to answer any questions and provide you with great, no-debate service support.

PROLUXE 

formerly DoughPro. New Name. Same Quality. Superior Service.

proluxe.com



TORTILLAPRO

Worlds Best Tortilla Press

DP2000BP Dual Heat Manual Tortilla Press

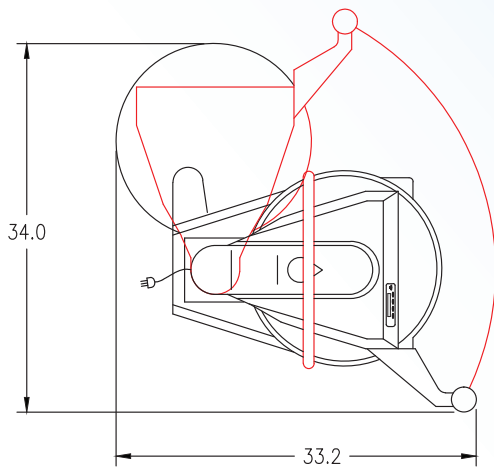

TOP VIEW

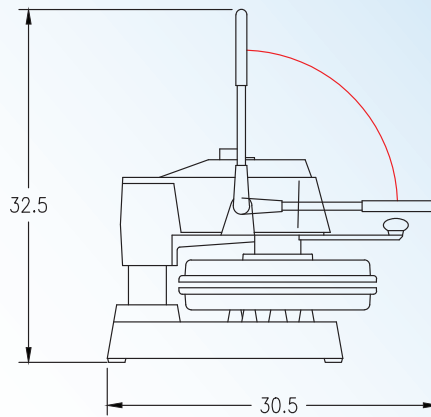

LEFT SIDE VIEW

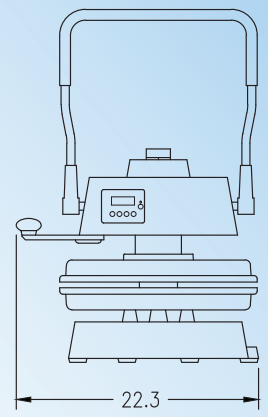

FRONT VIEW

ON/OFF Switch	Yes	Electrical Data 240v/50/60hz 2200w/11.66 amps
Programmable Timer	Yes	
Temperature Control	Yes	
Thickness Adjustment	Yes	Shipping Weight 175lbs/79kg
Maximum Heat	0-450 F	Machine Weight 140lbs/63kg

Includes 72" cord and NEMA 6-15 plug

Listed:



PROLUXE 

20281 Harvill Ave | Perris, CA 92570
t: (951) 657-0379 | t: (800) 624-6717 | f: (951) 657-4594
w: www.proluxe.com | e: info@prolux.com