



DCO3



DCO5

COUNTERTOP OVEN (DCO3&DCO5)

Doyon is proud to introduce their all new countertop ovens. The DCO3 & DCO5 are our smallest ovens with a three half-size sheet pans capacity (DCO3) and a five half-size sheet pans capacity (DCO5). Constructed of stainless steel, and a full view tempered glass door, the DCO3 & DCO5 are designed to be compact yet heavy-duty. Years of development helped us build units that will last for years of heavy use with minimal maintenance costs.

Their user-friendly control board makes them very simple to operate. Simply set the temperature and the timer and you are all set.

The DCO3 & DCO5 offer a great flexibility. They can produce bakery products, roast meats and cook meals.

Versatility:

Bread, rolls, buns, pastries, muffins, cakes, pies, bagels, croissants, soups and ryes, bacon, game hens, chicken, turkey, multimeal prep. and much more.

DCO3 & DCO5

*“Superior quality product
at an affordable price !”*

Doyon Countertop Oven

3 half-size pans baking capacity (DCO3)

5 half-size pans baking capacity (DCO5)

OVEN FEATURING

- Electromechanical controls
- Temperature up to 475 °F (245 °C)
- Indicator light for thermostat
- Door switch cutoff for fan blower
- Stainless steel construction
- 4” adjustable legs
- Press-fit removable door gasket for easy cleaning and replacement
- One-handed door handle operation
- Cool touch door with dual thermal wide view glass
- Lift up removable side racks
- Adjustable buzzer noise
- ETL and NSF listed
- One year parts and labor limited warranty

OPTIONAL

- Wire shelf (each)

OVERALL DIMENSIONS

DCO3 29 1/8" WX 27 7/8" D X 21 1/2" H
(740 mm X 708 mm X 546 mm)

DCO5 29 1/8" WX 27 7/8" D X 26 7/8" H
(740 mm X 708 mm X 683 mm)

Shelf spacing : DCO3 3 1/2" (89 mm)
DCO5 3 1/8" (85 mm)

ELECTRICAL SYSTEM

DCO3

1 phase:

120V- 16A -1.7 kW - 60 Hz NEMA 5-20P

DCO5

1 phase:

208V- 21A - 4 kW - 60 Hz

240V- 18A - 4 kW - 60 Hz

OVEN CAPACITY

DCO3

3 half-size (13"X18"- 330 mm X 457 mm) sheet pans

DCO5

5 half-size (13"X18"- 330 mm X 457 mm) sheet pans

FINISH

Stainless steel

SHIPPING INFORMATION

140 lb (64 kg) approximately (DCO3)

180 lb (82 kg) approximately (DCO5)

Electrical service connection is located at the back of the unit.

Specifications and design subject to change without notice.

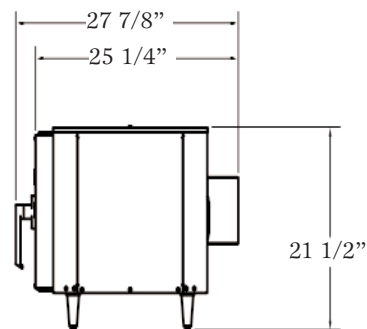
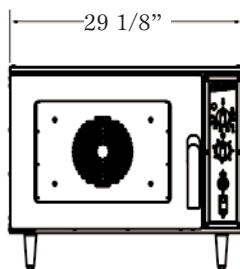

DCO3

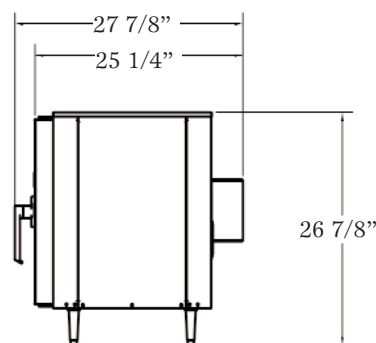
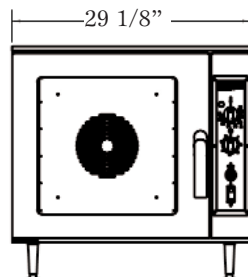

DCO5



Your local distributor:

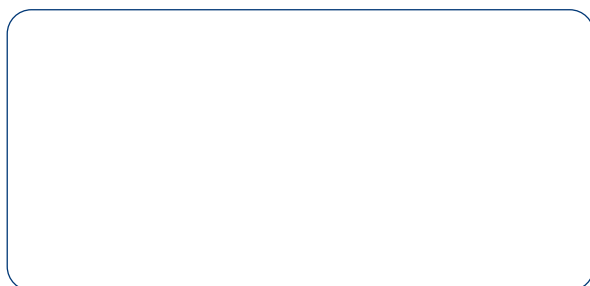

1255, rue Principale
Linière, Beauce, Québec, Canada G0M 1J0

Telephone : (418) 685-3431 Fax: (418) 685-3948
Canada : (800) 463-1636 U.S.: (800) 463-4273
E-Mail : doyon@doyon.qc.ca Internet: http://www.doyon.qc.ca