



JAOP10

JET AIR OVEN PROOFER JAOP10

The JAOP series from Doyon is known worldwide for its unique and patented Jet Air System (the air moves in one direction for 2.5 minutes, stops for 25 seconds then moves the other way for 2.5 minutes) resulting in a gentle velocity air flow for exceptional baking results. This system will help you bake faster and more evenly without having to turn your pans at half of the baking time. (Ex: Competitor units will bake only on one side or unevenly, muffins blow over, bakes only the outside, etc.). Our competitor ovens allow the air to move in one direction only. Doyon ovens will bake better and your employees will continue preparations without worrying about turning pans.

Doyon's outstanding uniform steam injection system includes an electronic timer which will give you a precise mist everytime for a better quality product (crusty breads, bagels, french baguettes, etc.). This superior steam system will allow inexperienced employees to produce quality products with a minimum of training.

Doyon's proofer provides uniform proofing from top to bottom with its even air flow system and fully automatic humidity injection (no water pans to fill). It comes with heat and humidity controls. It's the easiest way to proof.

VERSATILITY

Bread, rolls, buns, crusty breads, pastries, muffins, cookies, cakes, pies, bagels, croissants, sours & ryes, pizzas, hamburgers, bacon, game hens, chicken, turkey, multimeal prep, bulk vegetables, casseroles, slow cook, retherm.

JAOP10

“Simply the **best**
oven/proofer combination
on today's **market!**”

OVEN : 10 pans baking capacity

PROOFER : 12 pans capacity

OVEN FEATURING

- Exclusive patented reversing fan system
- Outstanding steam injection system including an electronic timer
- Compact space saving unit
- High production oven
- Full view heat reflective thermos glass doors
- Brightly lit
- Digital reminder timer
- Fully insulated, completely sealed
- Digital temperature controllers and timers
- Temperature up to a maximum of 500°F
- Energy efficient electric or gas heating (baking temperature reached in 15 minutes)
- Magnetic latches
- Door switch cut-off for fan blower
- Locking casters
- Stainless steel inside and outside
- 3/4 HP motor
- NSF & ETL listed
- One year parts and labor limited warranty

PROOFER FEATURING

- Glass doors
- Rust proof, scratch proof shelving
- Automatic water float system (no water pans to fill)
- Brightly lit
- Magnetic latches
- Stainless steel inside and outside

OPTIONAL

- Humidified warmer instead of proofer : temperature up to 250°F (100°C)
- Water softener system for installation
- Programmable controls (adds 2" to oven width)
- Automatic steam
- Delay switch (electric model only)
- Sliding doors

*All Jet Air ovens can
be used to cook meat*

DIMENSIONS

JAOP10	53 3/4" W X 49" D	X 73" H
	(136.5 cm) X (124.5 cm)	X (185.4 cm)
JAOP10G	53 3/4" W X 54" D	X 73" H
	(136.5 cm) X (137.2 cm)	X (185.4 cm)

OVEN INTERIOR DIMENSIONS

JAOP10	39 1/2" W X 31" D	X 26 1/2" H
	(100.3 cm) X (78.7 cm)	X (67.3 cm)
JAOP10G	39 1/2" W X 30" D	X 26 1/2" H
	(100.3 cm) X (76.2 cm)	X (67.3 cm)

Shelf spacing : 3 3/4" (9.5 cm)

PROOFER INTERIOR DIMENSIONS

39 1/2" W	X 30" D	X 27" H
(100.33 cm)	X (76.2 cm)	X (68.6 cm)

Shelf spacing : 3" (7.6 cm)

CAPACITY

Oven

Standard sheet pans 18" X 26" (45.7 cm X 66 cm) :	10 pans
Four-strapped bread pans :	36 loaves
9" (22.9 cm) :	50 pies
8" (20.3 cm) :	60 pies

Proofer

Standard sheet pans 18" X 26" (45.7 cm X 66 cm) :	12 pans
Four-strapped bread pans (up to 9 1/2" wide):	64 loaves

GAS SYSTEM (JAOP10G Propane or natural)

1 Phase:
 120/240V - 19.5 A - 4.5 kW - 3 wires - 60 Hz
 85 000 BTU
Gas Inlet : 1/2" NPT

Recommended gas pressure:

Propane gas : 11" W.C.
 Natural gas : 7" W.C.

ELECTRICAL SYSTEM (JAOP10)

1 Phase:
 120/240V - 70 A - 16.5 kW - 3 wires - 60 Hz
 220V - 81 A - 17.5 kW - 2 wires - 60 Hz
 3 Phases:
 120/208V - 50 A - 16.5 kW - 4 wires - 60 Hz
 220/380V - 32 A - 17.5 kW - 4 wires - 50 Hz
 220V - 48 A - 17.5 kW - 3 wires - 50 Hz

Other voltages available

Water Inlet : 1/4" NPT

FINISH

Stainless steel

SHIPPING WEIGHT

JAOP10	1175 lbs (533 kg) approximately
JAOP10G	1340 lbs (608 kg) approximately

Specifications and design subject to change without notice.

JAOP10

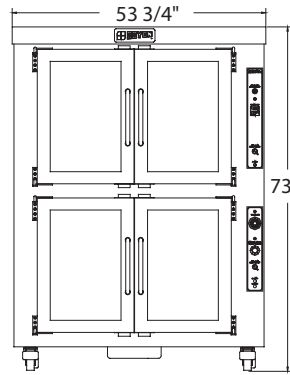

JAOP10G

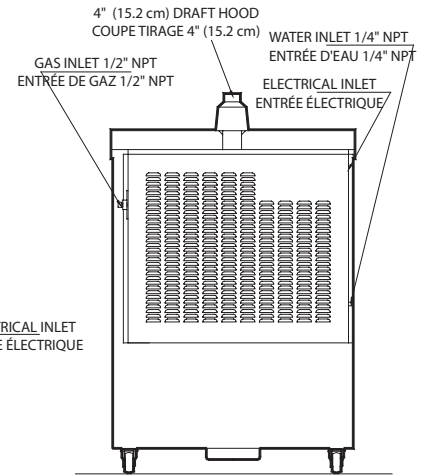
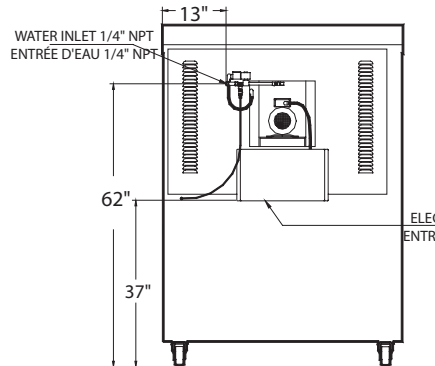
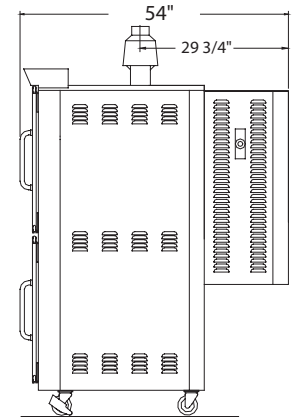
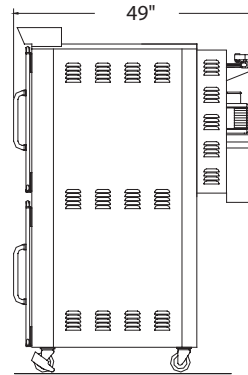
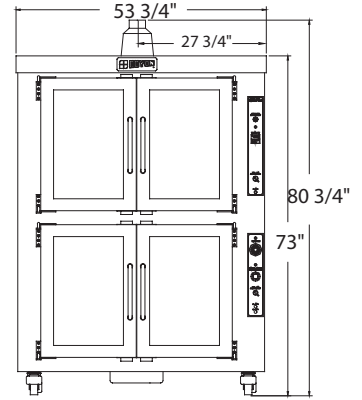

1255, rue Principale
 Linière, Beauce, Québec, Canada G0M 1J0

Telephone.: 418-685-3431
 Canada: 1-800-463-1636
 E-mail : doyon@doyon.qc.ca

Fax: 418-685-3948
 U.S.: 1-800-463-4273
 Internet : http://www.doyon.qc.ca



Your local distributor: / Votre distributeur:

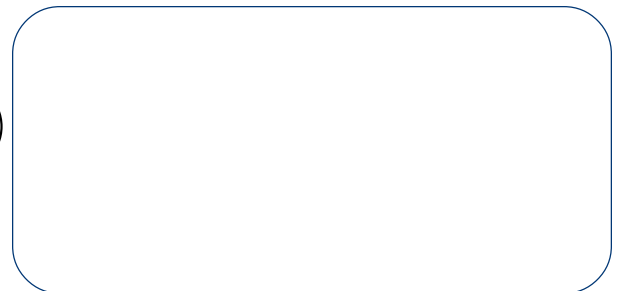

Printed in Canada Rev: 072003b