

**THINLINE SERIES**



**ROTATING RACK OVENS**  
**TLOI (single)**  
**TLOII (double)**  
 Ideal for baking, roasting,  
 holding and rethermalizing  
 food with minimal  
 moisture loss.



**DOYON THINLINE SERIES  
 (TLOI & TLOII RACK OVENS)**

Doyon's Thinline Rack Oven is simply your best buy for high volume production. You can either use the single rack (up to 18 shelves) or double rack oven (up to 36 shelves per load). These ovens are made of heavy duty stainless steel inside (430 series) and outside (304 series) for easy cleaning. They are brightly lit and come with a standard high volume steam injection system. Doyon's thinline series have standard suspended type racks (easy maintenance and cleaning, no messy rotating bearing on the floor), flat floor ramp for easy loading and unloading without tipping your products, front mounted panel for service and maintenance, space saving units (15% to 30% less floor space than our competitors: 49 1/2" X 49" single, 60 1/2" X 58 1/2" double). All our rack ovens are shipped in one piece (no need for costly technical personnel for assembly). Available in gas or electric.

## Compact

The TLO-I (single rack) and the TLO-II (doublerack) ovens are known as the best space saving units on the market. With floor dimensions of 49 1/2" X 49" (Single) or 60 1/2" X 58 1/2" (Double), the TLO's are ideal for any space conscious owner. Compare the Doyon rack ovens to the competing ones and notice that they take up less floor space and give greater capacity per square foot.

## Rack lifted for rotation

Doyon's exclusive TLO rack ovens are built to handle the heaviest loads. Racks are supported by the structural framework of the oven and the lifting device. Allows traditional double racks or side load single racks (2) to be raised gently and rotated automatically when the door is closed. The flush floor of the oven eliminates entry ramps for easy loading and unloading.

## Steam system

Doyon's outstanding high volume steam injection system includes an electronic timer which will give a precise uniform mist for a superior quality product (crusty breads, bagels, french baguettes, etc.). The heavy duty self contained steam generator is also known for its quick recovery.

## Air flow system

The unique and patented Jet Air system is standard with two vertical rows of adjustable stainless steel louvers. The air is gently blown across the products from two sides while your rack is rotating for a speedy 100% uniform baking. TLO ovens bring you the quality product expected from Doyon Equipment. Daily start-up time, 15 to 20 minutes.

## Oven door

Doyon rack ovens includes a full length 1/2" thick window with a halogene light offering bright product visibility. The door is fully insulated with an opening/closing mechanism that locks the top and bottom of the door (energy saving).

## Finish

TLO units are built with 430 series stainless steel inside and 304 series outside and are fully insulated .

## Versatility

- Bread, Rolls, Buns • Pastries • Cookies, Cakes • Bagels • Croissants • Sours and Ryes • Pizza
- Meats : Hamburgers, Bacon, Game hens, Chicken, Turkey
- Cook/Chill : Multi-Meal prep, Bulk vegetables/casseroles, Slow cook/Retherm

## Shipped fully assembled

Easy to set up, TLO rack ovens are up and running 3-4 hours after delivery as the oven requires no assembly. This saves you significant down time during installation . Shipped on a pallet with welded heavy duty eye bolt mounted on top of oven (easy erecting).

## SHIPPING INFORMATION

<b>TLOIE</b>	2600 lbs (1180 kg) approximately
<b>TLOIE</b>	3600 lbs (1635 kg) approximately
<b>TLOIG</b>	2600 lbs (1180 kg) approximately
<b>TLOIG</b>	3600 lbs (1635 kg) approximately

## Accurate heavy duty controls

- Digital baking timer
- Digital steam timer
- Digital thermostat
- Optional digital programmable control
- Emergency stop
- On / Off switch
- Preheat press button (up to 600°F)
- Preheat button is luminous
- Baking temperature 500°F max



**Taller load**

The TLO gives you from 10% to 25% more production per load than other rack ovens (see rack specifications). This means more production and less spending in labor and energy costs.

**Serviceable from front**

Service connections are easy to access from the front of the unit.

**Approvals**

Tested and approved by the major health and safety approval agencies for gas and electric commercial cooking appliances.

**Ventilation hood**

TLO rack ovens come with standard type II hoods to satisfy local and national codes.

**Options**

Contact factory for optional features

**Service**

Doyon ovens are built to last with the ISO quality standards. We have qualified service/installation agencies throughout the world.

**RTLOII**



**RTLOI**



**RACK SPECIFICATIONS**

**RTLOI**

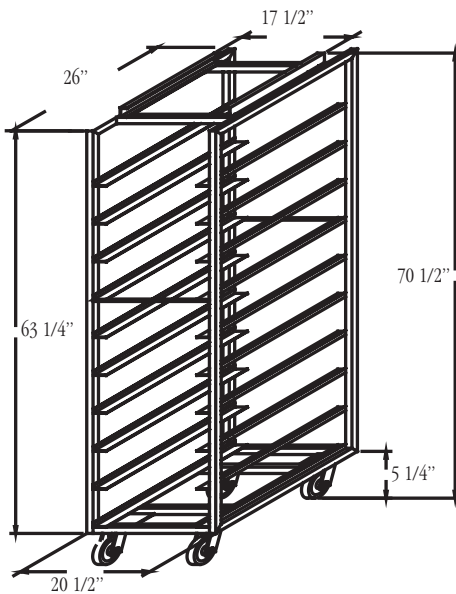

**RTLOSL**

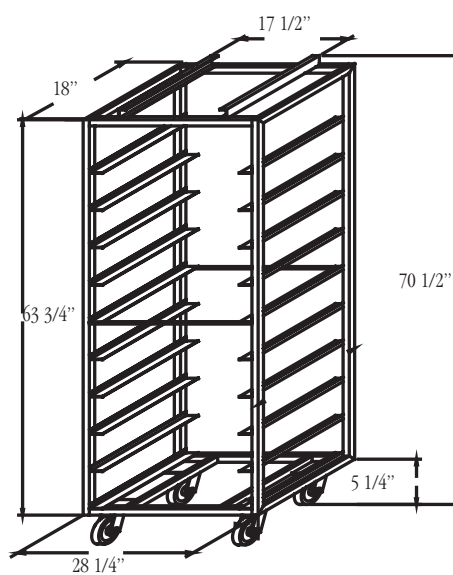

**RTLOII**

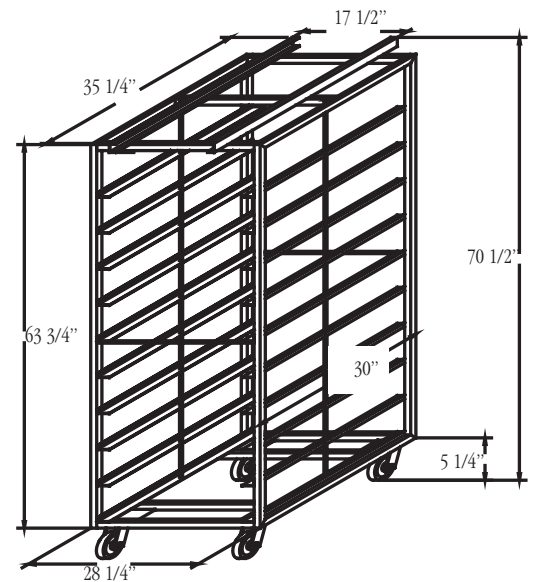

PAN QTY	SPACING
10	6 3/16"
11	5 9/16"
12	5 1/8"
13	4 3/4"
15	4 1/16"
18	3 3/8"

PAN QTY	SPACING
10	6 3/16"
11	5 9/16"
12	5 1/8"
13	4 3/4"
15	4 1/16"
18	3 3/8"

PAN QTY	SPACING
20	6 3/16"
22	5 9/16"
24	5 1/8"
26	4 3/4"
30	4 1/16"
36	3 3/8"

**OVERALL DIMENSIONS**

TLOIE : 49 1/2" W X 106" H X 72 1/2" D  
 (126 cm) (269 cm) (184.2 cm)  
 TLOIG : 49 1/2" W X 106" H X 72 1/2" D  
 (126 cm) (269cm) (184.2 cm)  
 TLOIEE : 60 1/2" W X 106" H X 82 1/2" D  
 (153.5 cm) (269 cm) (209.5 cm)  
 TLOIIG : 60 1/2" W X 106" H X 82 1/2" D  
 (153.5cm) (269cm) (209.5 cm)

**OVEN INTERIOR DIMENSIONS (wall to wall)**

TLOIE : 37" W X 75" H X 39" D  
 (94 cm) (190 cm) (99 cm)  
 TLOIG : 37" W X 75" H X 39" D  
 (94 cm) (190 cm) (99 cm)  
 TLOIEE : 48" W X 75" H X 50" D  
 (122 cm) (190 cm) (127 cm)  
 TLOIIG : 48" W X 75" H X 50" D  
 (122 cm) (190 cm) (127 cm)

**ELECTRICAL SYSTEM**

TLOIE 3 phases:  
 120/208V - 122A - 44kW - 4 wires - 60 Hz  
 120/240V - 105A - 44kW - 4 wires - 60 Hz  
 220/380V - 74A - 49kW - 4 wires - 50 Hz  
 480V - 52A - 44kW - 3 wires - 60 Hz  
 600V - 42A - 44kW - 3 wires - 60 Hz

TLOIEE 3 phases:  
 480V - 75A - 62kW - 3 wires - 60 Hz  
 600V - 60A - 62kW - 3 wires - 60 Hz  
 220/380V - 94A - 62kW - 4 wires - 50 Hz

TLOIG 3 phases:  
 120/208V - 8A - 3kW - 4 wires - 60 Hz  
 120/240V - 10A - 3kW - 4 wires - 60 Hz  
 220/380V - 4.1A - 2.7kW - 4 wires - 50 Hz

Gas Info : 200 000 BTUH (Propane or Natural)

TLOIIG 3 phases:  
 120/208V - 10A - 3.5kW - 4 wires - 60 Hz  
 120/240V - 10A - 3.5kW - 4 wires - 60 Hz  
 220/380V - 5.1A - 3.3kW - 4 wires - 50 Hz

Gas Info : 300 000 BTUH (Propane or Natural)

**Recommended gas pressure:**

Propane gas : 11" W.C.  
 Natural gas : 7" W.C.

**INSTALLATION**

- Unit must be on a level floor. Not approved for installation on combustible floor surfaces.
- Certified for zero clearance to combustible surface sides and back.
- Drain required (located in the back of the unit, close to the floor)
- Nine feet minimum ceiling
- Draft hood included with all models

Specifications and design subject to change without notice.

**TLOI**

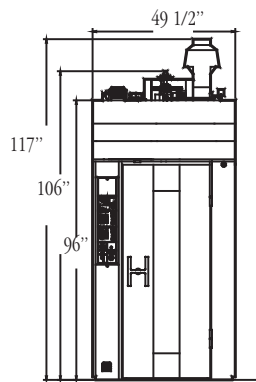

**TLOIE**

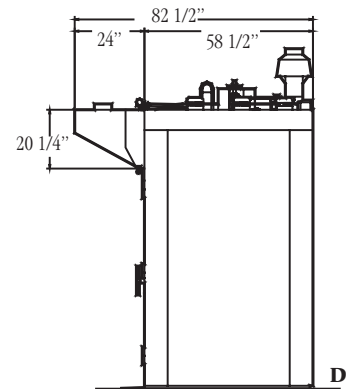
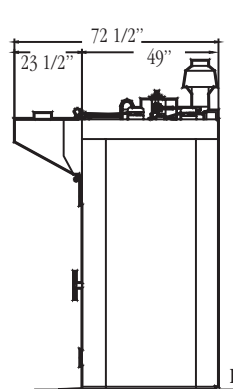
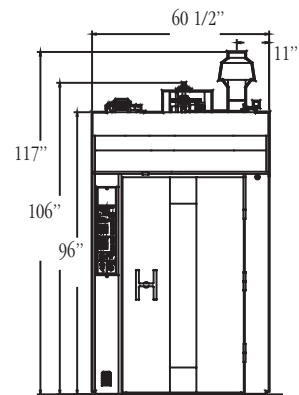

**Top View**

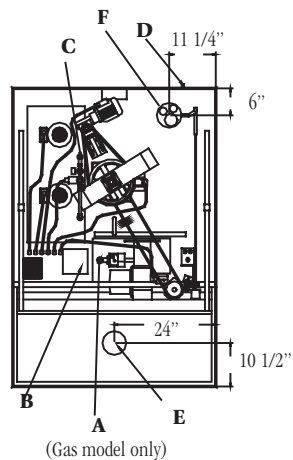

(Gas model only)

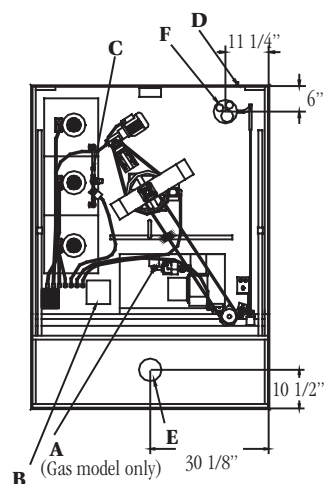

(Gas model only)

A: Gas inlet 3/4" NPT  
 C: Water inlet 1/4" NPT  
 E: Oven hood vent : 6"

B: Electrical inlet  
 D: 1/2" drain  
 F: 6" diameter gas flue exhaust

Your local distributor:

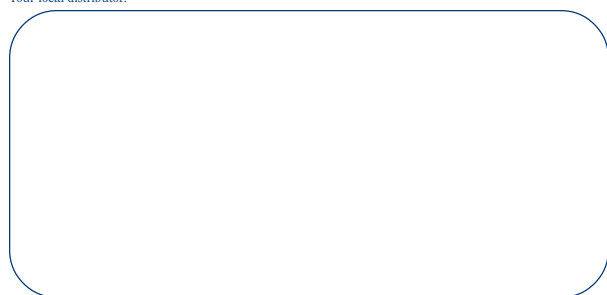

1255, rue Principale  
 Linière, Beauce, Québec, Canada G0M 1J0

Telephone.: 418-685-3431  
 Canada: 1-800-463-1636  
 E-mail : doyon@doyon.qc.ca

Fax: 418-685-3948  
 U.S.: 1-800-463-4273  
 Internet : http://www.doyon.qc.ca