

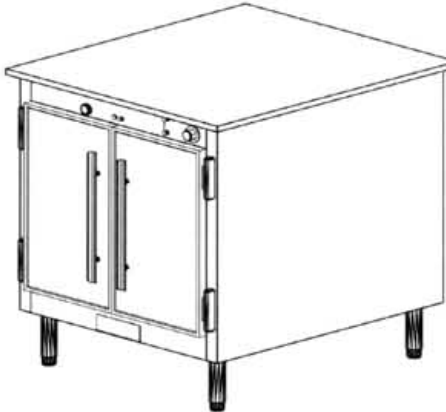

"Your Solutions Partner"

Specifications

F.O.B. St. Louis, Missouri 63102



1151

OPTIONS:

- Enclosed base - 6" high
- Cord and plug - 8'
- Casters - 5" polyurethane, 2 swivel w/brakes/2 rigid
- Push bar
- Bumpers - stainless steel
- Door Panels - laminated plastic
- Additional pair 5" angle slides
- Door locks
- 440-480V Circuit
- Celsius thermometer in lieu of Fahrenheit
- 208V/1Ph; 208V/3Ph; 240V/1Ph; 240V/3Ph

AGENCY LISTINGS:



DUKE MANUFACTURING CO.
2305 N. Broadway
St. Louis, MO 63102

800.735.3853 Toll Free
314.231.1130 In Missouri
314.231.5074 Fax
www.dukemfg.com

Approval Stamp(s):

PROJECT INFORMATION:

PROJECT: _____
 ITEM: _____
 QUANTITY: _____

MODEL:

Thermotainer Food Holding Cabinets - "E" Series 21"H x 22"W x 28-1/2"D Compartments

- 1151** Reach-In - 1 thermostat, with legs
- 1151P** Pass-Thru - 1 thermostat, with legs

BODY:

- Heavy gauge stainless steel, all panels except bottom
- Shell welded to interior
- Die-stamped compartment openings
- Top 14 ga. S/S w/1" turned down edge and 1" overhang on all sides

DOORS:

- Stainless steel Uni-Door construction
- Operate simultaneously, either opening or closing
- Overhead operating unit
- Automatic stop holds open position
- Spring hinges die-stamped, with built-in stop externally adjustable, completely concealed

COMPARTMENT:

- Heavy gauge stainless steel
- Rounded corners
- Stainless steel studs for angle slides at 9 levels
- (4) removable, adjustable, stainless steel, 5" angle slide pairs
- Removable liner for inspection and maintenance

ELECTRICAL CONTROLS:

- Recessed thermostat w/built-in On-Off switch
- Heat range 100°-300°F and dial thermometer
- Pilot lights
- Recessed connection box
- Thermostat, pilot lights set in removable access panel

DAMPERS:

- 2-position sliding type
- Controlled by push buttons
- Compartments individually controlled

INSULATION:

- Body fully insulated with 1-1/2" fiberglass, doors with fiberglass

HEATING ELEMENTS:

- Sheath type strip heaters, 120 Volt, 1 Phase
- Removable compartment for ease of access to heating element

LEGS:

- Stainless steel die-stamped adjustable legs - 6" high

SHORT FORM SPECIFICATIONS:

Duke Thermotainers Food Holding Cabinets. Models 1151/1151P constructed with one (1) compartment. Compartment 21"H x 22"W x 28-1/2"D. Compartment to have four (4) pairs of removable stainless steel slides. One thermostat controls compartment. 100°-300°F heat range with dial thermometer and 6" high stainless legs. Built-in installation - allow 1/4" tolerance greater than body width.



THERMOTAINER FOOD HOLDING CABINETS - "E" SERIES
21"H x 22"W x 28-1/2"D COMPARTMENTS

- 1151** Reach-In - 1 thermostat, with legs
- 1151P** Pass-Thru - 1 thermostat, with legs

LEGEND	
▲	ELECTRICAL CONNECTION

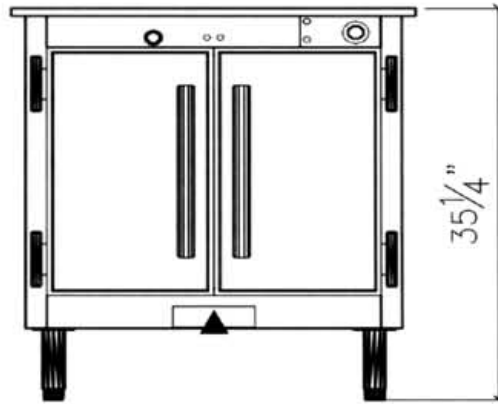
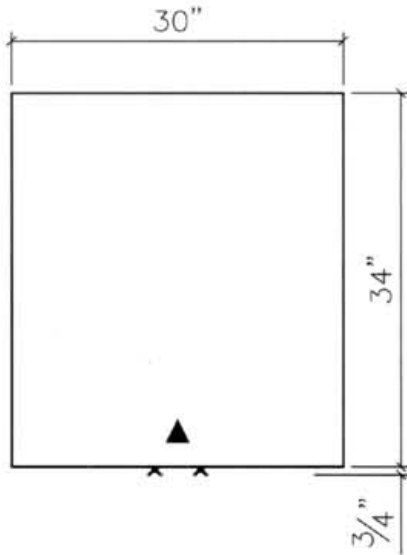

A.I.A. File No. 35-C-13

Catalog No. THERMO-1151

THERMOTAINER FOOD HOLDING CABINETS - "E" SERIES - 1151

DIMENSIONS:

Freight Class: 100

Model	Width		Depth		Height		Comp. Depth		Cube ft. crated	Weight	
	in.	cm	in.	cm	in.	cm	in.	cm		lbs.	kg
1151	30	76.2	34-3/4	88.3	35-1/4	89.5	28-1/2	72.4	34.9	300	136.4
1151P	30	76.2	35-1/2	90.2	35-1/4	89.5	30-1/2	77.5	35.6	300	136.4

ELECTRICAL SPECIFICATIONS: (Consult factory for 3-phase electrical requirements and other options.) 120V, 1Ph

Model	Connected Load
1151	1500 watts
1151P	1500 watts

	1151/1151P
Capacity w/standard slides	(14) 12" x 20" x 2" pans or (8) 12" x 20" x 4" pans or (4) 12" x 20" x 8" pans or (10) 18" x 26" bake sheets

- 1151** Reach-In - hinged Uni-Doors on front only
- 1151P** Pass-Thru - hinged Uni-Doors on front & back for pass-thru service.



DUKE MANUFACTURING CO.
 2305 N. Broadway
 St. Louis, MO 63102

800.735.3853 Toll Free
 314.231.1130 In Missouri
 314.231.5074 Fax
www.dukemfg.com

"Your Solutions Partner"

Specifications subject to change

08/03

Printed in U.S.A.
 ©2003, Duke Manufacturing Co.