



Profit from the Eagle Advantage®

Specification Sheet

Short Form Specifications

Eagle Panco® Half Size Mobile Can Rack, with aluminum top, model _____. All-welded aluminum construction, crossbraced front-to-back and side-to-side. Aluminum angle racks secured to frame at a slight angle to allow for gravity feed. Furnished with 4"-diameter casters. Capacity to be (54, 72) #10 cans or (72, 96) #5 cans.

Eagle Panco® Half Size Mobile Can Rack, with 1/2"-thick polymer top, model _____. All-welded aluminum construction crossbraced front-to-back and side-to-side. Aluminum angle racks secured to frame at a slight angle to allow for gravity feed. Furnished with 4"-diameter casters. Capacity to be (54, 72) #10 cans or (72, 96) #5 cans.



model #OCR-10-4A
can rack with
aluminum top

Options / Accessories

- Casters with locking brakes
- Perimeter bumpers
- Vertical corner bumpers

EAGLE GROUP

100 Industrial Boulevard, Clayton, DE 19938-8903 USA
Phone: 302-653-3000 • Fax: 302-653-2065
www.eaglegrp.com

Foodservice Division: Phone 800-441-8440

MHC/Retail Display Divisions: Phone 800-637-5100

For custom configuration or fabrication needs, contact our **SpecFAB®** Division.

Phone: 302-653-3000 • Fax: 302-653-3091 • e-mail: specfab@eaglegrp.com

Item No.: _____
Project No.: _____
S.I.S. No.: _____

Panco® Can Racks —Half Size

MODELS:

- OCR-10-3A
- OCR-10-4A
- OCR-10-3AP
- OCR-10-4AP

Design and Construction Features

- All-welded construction. All racks are constructed of high-strength aluminum sections.
- Frame and supports: square aluminum tubing. Crossbraced front-to-back and side-to-side on top and bottom of unit.
- Rack slides made from aluminum angles secured to frame at a slight angle for gravity feed.
- Casters: 4" (127mm)-diameter non-marking swivel plate casters with polymer tread.
- Offered with aluminum or 1/2" (13mm)-thick poly top.
- Provides automatic stock rotation when loaded from rear.
- Shipped assembled.

Certifications / Approvals



EG60.15B Rev. 08/08

Spec sheets available for viewing, printing or downloading from our online literature library at www.eaglegrp.com

Eagle Foodservice Equipment, Eagle MHC, SpecFAB®, and Retail Display are divisions of Eagle Group. ©2008 by the Eagle Group



Profit from the Eagle Advantage®

Item No.: _____
 Project No.: _____
 S.I.S. No.: _____

Panco® Can Racks—Half Size

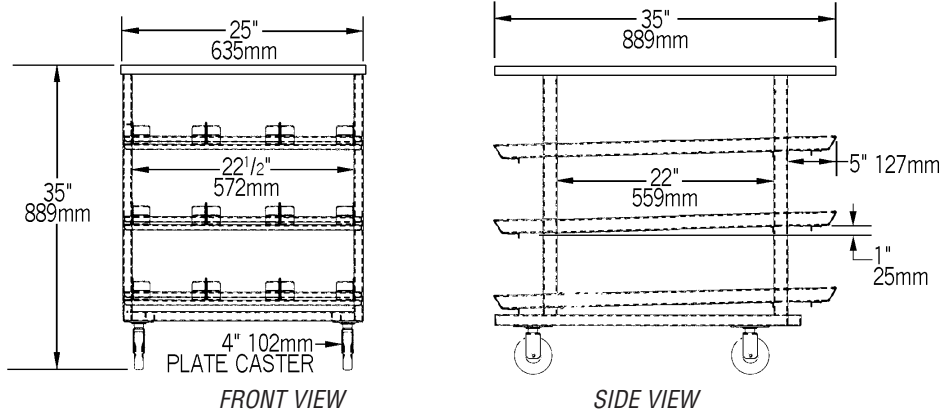

(#OCR-10-3A shown)

Racks with Aluminum Top

model #	description	overall dimensions						sliding space		can capacity		# of tiers high	weight	
		width in.	width mm	depth in.	depth mm	height in.	height mm	in.	mm	#10	#5		lbs.	kg
OCR-10-3A	half size, mobile	25"	635	35"	889	35"	889	7 1/2"	191	54	72	3	39	17.6
OCR-10-4A	half size, mobile	25"	635	35"	889	41"	1041	7 1/2"	191	72	96	4	36	16.3

Racks with 1/2" (13mm)-thick Poly Top

model #	description	overall dimensions						sliding space		can capacity		# of tiers high	weight	
		width in.	width mm	depth in.	depth mm	height in.	height mm	in.	mm	#10	#5		lbs.	kg
OCR-10-3AP	half size, mobile	25 1/2"	648	35 1/2"	892	32 3/4"	822	7 1/2"	191	54	72	3	51	23.1
OCR-10-4AP	half size, mobile	25 1/2"	648	35 1/2"	892	40 3/4"	1038	7 1/2"	191	72	96	4	54	24.5

EAGLE GROUP
 100 Industrial Boulevard, Clayton, DE 19938-8903 USA
 Phone: 302-653-3000 • Fax: 302-653-2065
 www.eaglegrp.com

Foodservice Division: Phone 800-441-8440
 MHC/Retail Display Divisions: Phone 800-637-5100

Printed in U.S.A.
 ©2008 by Eagle Group

Rev. 08/08

Spec sheets available for viewing, printing or downloading from our online literature library at www.eaglegrp.com

Although every attempt has been made to ensure the accuracy of the information provided, we cannot be held responsible for typographical or printing errors. Information and specifications are subject to change without notice. Please confirm at time of order.