



Profit from the Eagle Advantage®

# Specification Sheet

## Short Form Specifications

Constructed of 1" square tubular aluminum frame and supports. 1 1/2" x 1 1/2" extruded aluminum tray slides with two raised beads to minimize friction. Slides are welded to vertical posts. Slide spacing to be 2" to accommodate 30 full size sheet pans. Furnished with 5"-diameter casters. Front-loading and side-loading models available. Shipped assembled. 69 1/4" height and features open top.



all-welded unit  
#OUR-1830-2/W

## Options / Accessories

Aluminum tray

## EAGLE GROUP

100 Industrial Boulevard, Clayton, DE 19938-8903 USA

Phone: 302-653-3000 • Fax: 302-653-2065

www.eaglegrp.com

Foodservice Division: Phone 800-441-8440

MHC/Retail Display Divisions: Phone 800-637-5100

For custom configuration or fabrication needs, contact our **SpecFAB®** Division.

Phone: 302-653-3000 • Fax: 302-653-3091 • e-mail: specfab@eaglegrp.com

Item No.:	_____
Project No.:	_____
S.I.S. No.:	_____

## All-Welded Units with Solid Tray Racks

### MODELS:

OUR-1830-2/W

OUR-2630-2/W

### Design and Construction Features

- Heavy duty all-welded aluminum construction.
- Frame and supports are 1" (25mm) square aluminum tubing with 0.063" (2mm) wall.
- Tray slides are extruded aluminum angle, 1 1/2" high x 1 1/2" wide x 0.068" thick (29 x 41 x 2mm), bearing surface with two raised beads providing a minimum of friction. Slides are welded to vertical posts.
- 5" (127mm)-diameter NSF-approved, non-marking swivel stem plated casters with polymer tread.
- Front load and side load models available.
- 69 1/4" (1759mm) overall height.



Profit from the Eagle Advantage®

Item No.: \_\_\_\_\_  
 Project No.: \_\_\_\_\_  
 S.I.S. No.: \_\_\_\_\_

## All-Welded Units with Solid Tray Racks

### Front load unit

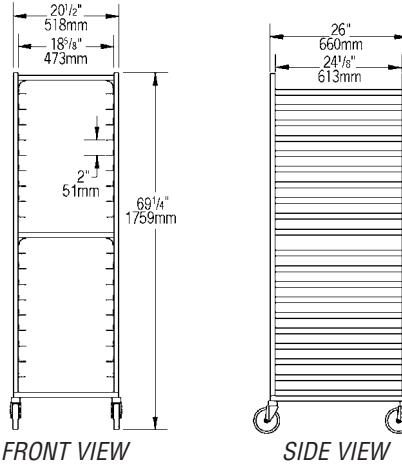

model #	overall dimensions			sliding space	full size pan capacity	weight	
	width	depth	height			in. mm	lbs. kg
OUR-1830-2/W	20 1/2" 521	26" 660	69 1/4" 1759	2" 51	30	47	21.3

### Side load unit

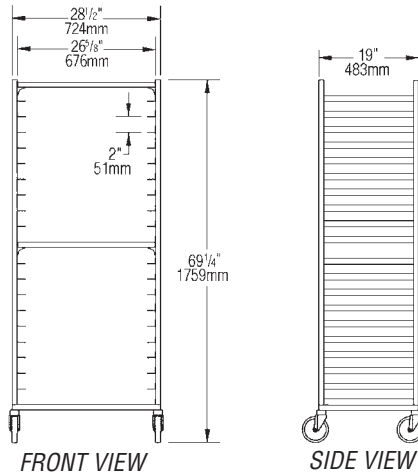

model #	overall dimensions			sliding space	full size pan capacity	weight	
	width	depth	height			in. mm	lbs. kg
OUR-2630-2/W	28 1/2" 724	19" 483	69 1/4" 1759	2" 51	30	32	14.5

**EAGLE GROUP**  
 100 Industrial Boulevard, Clayton, DE 19938-8903 USA  
 Phone: 302-653-3000 • Fax: 302-653-2065  
 www.eaglegrp.com

Foodservice Division: Phone 800-441-8440  
 MHC/Retail Division: Phone 800-637-5100

Printed in U.S.A.  
 ©2009 by Eagle Group  
 Rev. 02/09

Spec sheets available for viewing, printing or downloading from our online literature library at [www.eaglegrp.com](http://www.eaglegrp.com)

Although every attempt has been made to ensure the accuracy of the information provided, we cannot be held responsible for typographical or printing errors. Information and specifications are subject to change without notice. Please confirm at time of order.