



Profit from the Eagle Advantage®

Specification Sheet

Short Form Specifications

Eagle Panco® Pizza Dough Box Rack, model OUR-DB-7A. All-welded aluminum construction with 1" square tubular frame and supports. Crossbracing runs side-to-side and front-to-back on top and bottom. 1 1/16" x 1 1/8" extruded aluminum slides with two raised beads to minimize friction. 3 1/2" slide spacing accommodates seven 18" x 26" pizza dough boxes. Furnished with 5"-diameter casters. Shipped assembled.



pizza dough box rack

Options / Accessories

- Casters with locking brakes
- Rotary bumpers
- Perimeter bumper
- Vertical corner bumpers
- Pan stop

EAGLE GROUP
100 Industrial Boulevard, Clayton, DE 19938-8903 USA
Phone: 302-653-3000 • Fax: 302-653-2065
www.eaglegrp.com

Foodservice Division: Phone 800-441-8440
MHC/Retail Display Divisions: Phone 800-637-5100

For custom configuration or fabrication needs, contact our **SpecFAB® Division**.
Phone: 302-653-3000 • Fax: 302-653-3091 • e-mail: specfab@eaglegrp.com

Item No.:	_____
Project No.:	_____
S.I.S. No.:	_____

Panco® Pizza Dough Box Rack

MODELS:

- OUR-DB-7A
- PDB
- PDBC

Features on Pizza Dough Box Rack

- Heavy duty all-aluminum welded frame construction with solid top.
- Frame and supports: 1" (25mm) square aluminum tubing. Crossbracing runs side-to-side and front-to-back on top and bottom of unit.
- Tray slides: extruded aluminum angle 1 1/16" high x 1 1/8" wide x .068" thick (37 x 48 x 2mm) bearing surface with two raised beads to minimize friction. Slides are riveted to frame.
- Casters: 5" (127mm)-diameter non-marking swivel stem casters with polymer tread.
- Shipped assembled.

Features on Pizza Dough Box and Cover (sold separately)

- Made of durable thermoplastic.
- Stackable design.
- 12 per carton.



Spec sheets available for viewing, printing or downloading from our online literature library at www.eaglegrp.com



Profit from the Eagle Advantage®

Item No.: _____
 Project No.: _____
 S.I.S. No.: _____

Panco® Pizza Dough Box Rack

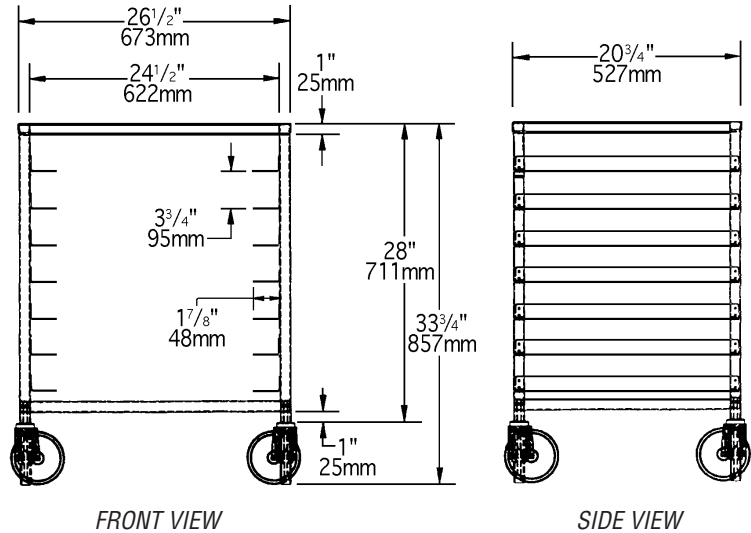

model #	overall dimensions						sliding space		box capacity	weight	
	width in.	width mm	depth in.	depth mm	height in.	height mm	in.	mm		lbs.	kg
OUR-DB-7A	26 1/2"	673	20 3/4"	527	33 3/4"	857	3 3/4"	95	7	27	12.3

Pizza Dough Box and Cover

model #	description	overall dimensions						weight	
		width in.	width mm	depth in.	depth mm	height in.	height mm	lbs.	kg
PDB	pizza dough box	18"	457	26"	660	3"	76	46	20.9
PDBC	cover	18"	457	26"	660	n/a		14	6.4

EAGLE GROUP
 100 Industrial Boulevard, Clayton, DE 19938-8903 USA
 Phone: 302-653-3000 • Fax: 302-653-2065
 www.eaglegrp.com

Foodservice Division: Phone 800-441-8440
 MHC/Retail Display Divisions: Phone 800-637-5100

Printed in U.S.A.
 ©2008 by Eagle Group

Rev. 08/08

Spec sheets available for viewing, printing or downloading from our online literature library at www.eaglegrp.com

Although every attempt has been made to ensure the accuracy of the information provided, we cannot be held responsible for typographical or printing errors. Information and specifications are subject to change without notice. Please confirm at time of order.