



Profit from the Eagle Advantage®

Specification Sheet

Short Form Specifications

Eagle Cup Tower, model TSC3036Z, to consist of four 3036Z EAGLEbrite® zinc-plated wire shelves with 74" EAGLEbrite® zinc-plated posts, and 10 rods & tabs.

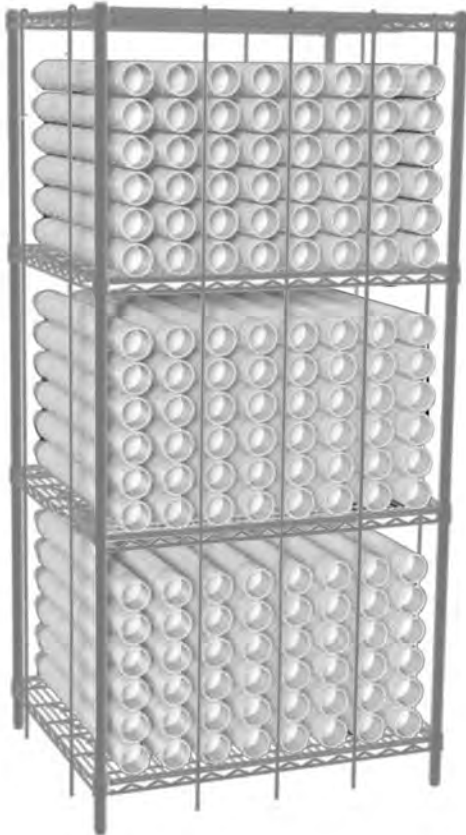

(shown propped)

Options / Accessories

- Foot plates
- Shelf ledges
- Shelf shelving dividers
- Plastic shelf markers
- Add'l rods & tabs

EAGLE GROUP

100 Industrial Boulevard, Clayton, DE 19938-8903 USA

Phone: 302-653-3000 • Fax: 302-653-2065

www.eaglegrp.com

Foodservice Division: Phone 800-441-8440

MHC/Retail Display Divisions: Phone 800-637-5100

For custom configuration or fabrication needs, contact our SpecFAB® Division.

Phone: 302-653-3000 • Fax: 302-653-3091 • e-mail: specfab@eaglegrp.com

Item No.:	_____
Project No.:	_____
S.I.S. No.:	_____

Cup Tower

MODELS:

- TSC3036Z

- Flexible design allows for custom look using standard components.
- Allows for easy inventory count.
- Easy identification of product.
- Four 30" x 36" (762 x 914mm) zinc-plated wire shelves with patented QuadTruss® design (patent #5,390,803). Shelf height can be adjusted.
- Ten chrome-plated full-height rods & tabs for ease of organization. Can be attached anywhere along shelf trusses without the need for tools.
- 74" (1880mm) overall post height.
- All posts are numbered and grooved at 1" (25mm) increments for fast and level assembly.





Item No.: _____
 Project No.: _____
 S.I.S. No.: _____

Cup Tower

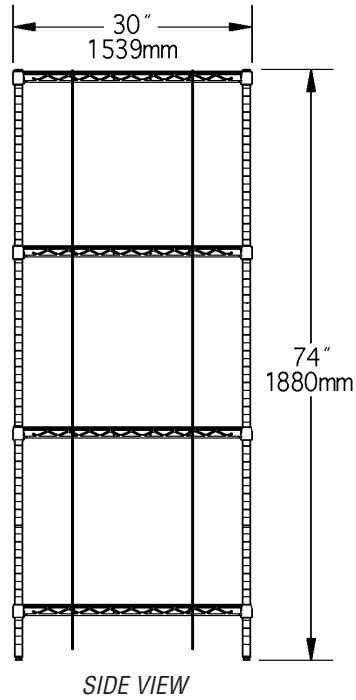
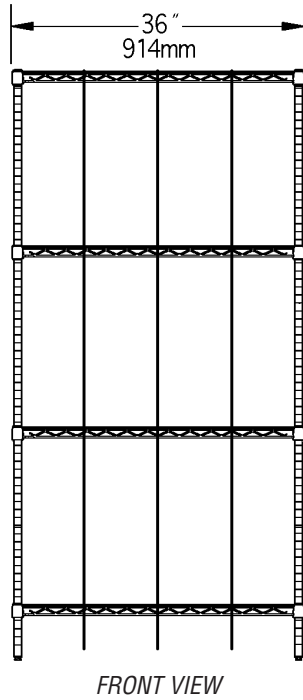
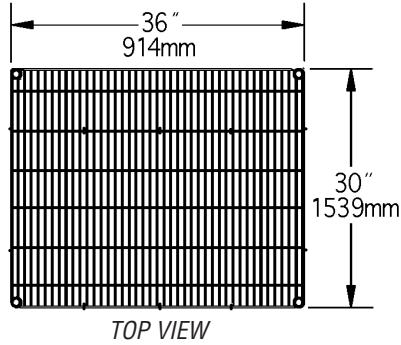

model #	width		length		height		weight	
	in.	mm	in.	mm	in.	mm	lbs.	kg
TSC3036Z	30"	762	36"	914	74"	1880	104	47.2

EAGLE GROUP
 100 Industrial Boulevard, Clayton, DE 19938-8903 USA
 Phone: 302-653-3000 • Fax: 302-653-2065
 www.eaglegrp.com

Foodservice Division: Phone 800-441-8440
 MHC/Retail Display Divisions: Phone 800-637-5100

Printed in U.S.A.
 ©2010 by Eagle Group
 Rev. 11/10

Spec sheets available for viewing, printing or downloading from our online literature library at www.eaglegrp.com

Although every attempt has been made to ensure the accuracy of the information provided, we cannot be held responsible for typographical or printing errors. Information and specifications are subject to change without notice. Please confirm at time of order.