



# EM Series Gas French Top 36"

ITEM # \_\_\_\_\_

MODEL # \_\_\_\_\_

PROJECT NAME # \_\_\_\_\_

SIS # \_\_\_\_\_

AIA# \_\_\_\_\_

Electrolux

EM Series  
Gas French Top 36"

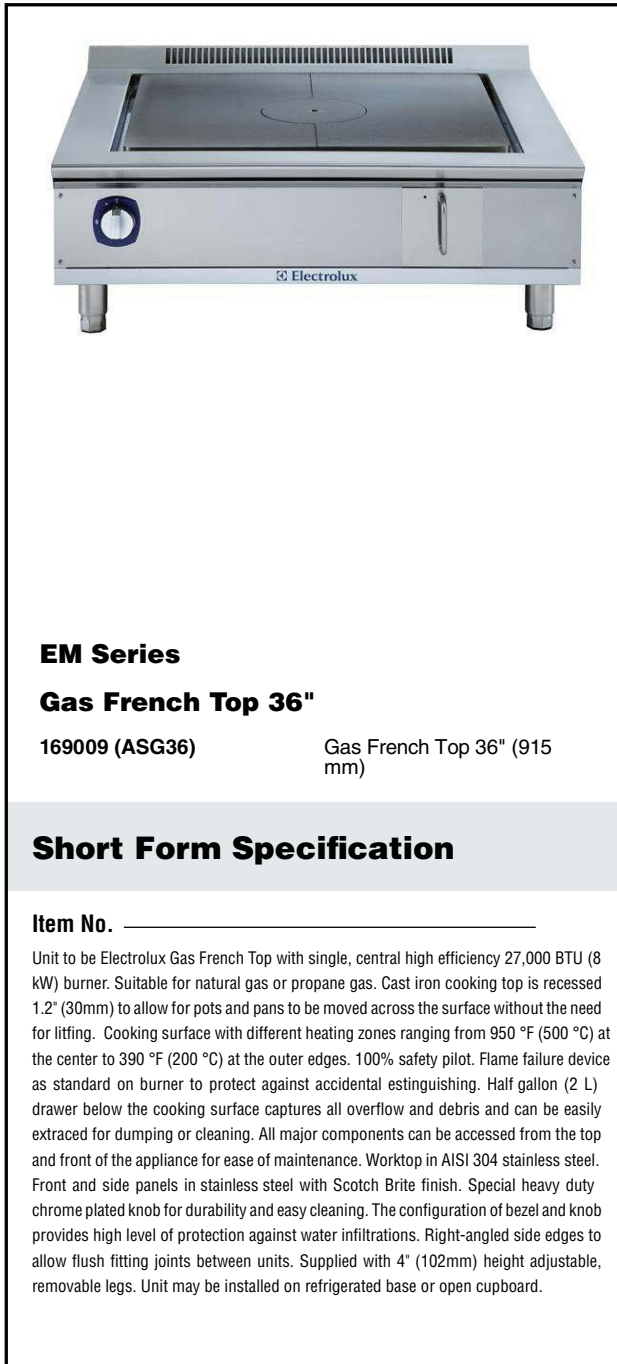

### EM Series

### Gas French Top 36"

169009 (ASG36)

Gas French Top 36" (915 mm)

### Short Form Specification

Item No. \_\_\_\_\_

Unit to be Electrolux Gas French Top with single, central high efficiency 27,000 BTU (8 kW) burner. Suitable for natural gas or propane gas. Cast iron cooking top is recessed 1.2" (30mm) to allow for pots and pans to be moved across the surface without the need for lifting. Cooking surface with different heating zones ranging from 950 °F (500 °C) at the center to 390 °F (200 °C) at the outer edges. 100% safety pilot. Flame failure device as standard on burner to protect against accidental extinguishing. Half gallon (2 L) drawer below the cooking surface captures all overflow and debris and can be easily extraced for dumping or cleaning. All major components can be accessed from the top and front of the appliance for ease of maintenance. Worktop in AISI 304 stainless steel. Front and side panels in stainless steel with Scotch Brite finish. Special heavy duty chrome plated knob for durability and easy cleaning. The configuration of bezel and knob provides high level of protection against water infiltrations. Right-angled side edges to allow flush fitting joints between units. Supplied with 4" (102mm) height adjustable, removable legs. Unit may be installed on refrigerated base or open cupboard.

### Main Features

- Single, central high efficiency 27,000 BTU (8 kW) gas burner.
- Durable cast iron cooking plate, easy to clean.
- Cast iron cooking top is recessed 1.2" (30mm) to allow for pots and pans to be moved across the surface without the need for lifting. Cooking surface with different heating zones ranging from 950 °F (500 °C) at the center to 390 °F (200 °C) at the outer edges.
- Removable circular ring positioned at center of cooking surface and directly over the burner.
- Half gal. (2 l) drawer below the cooking surface captures all overflow and debris and can be easily extraced for dumping or cleaning.
- Flame failure device protects against accidental extinguishing of the flame.
- 100% safety pilot.
- All major components can be accessed from the top and front of the appliance for ease of maintenance.
- Worktop in AISI 304 stainless steel.
- Front and side panels in stainless steel with Scotch Brite finish.
- Special heavy duty chrome plated knob for durability and easy cleaning.
- The configuration of bezel and knob provides high level of protection against water infiltrations.
- Right-angled side edges to allow flush fitting between units.
- Provided with kit for side-by-side connection between units for minimizing gaps and possible dirt traps.
- Supplied with 4" (102mm) height adjustable, removable legs.
- Unit may be installed on refrigerated base by removing the legs and inserting the special pins (optional accessory model # 169048).
- Unit may be installed on open cupboard by removing the legs and inserting the srews provided as standard with the open cupboards.
- Included accessories: propane converter kit, pressure regulator, main shut off valve and hook for removal of cooking surface central ring.

### Optional Accessories

- KIT 4 PINS TO FIX TOP EQUIP.TO REF.BASE PNC 169048



Approval: \_\_\_\_\_

**Electrolux Professional, Inc.**

[www.electroluxusa.com/professional](http://www.electroluxusa.com/professional)

10200 David Taylor Drive, Charlotte, NC 28262 • Telephone Number: 866-449-4200 • Fax Number: 704-547-7401

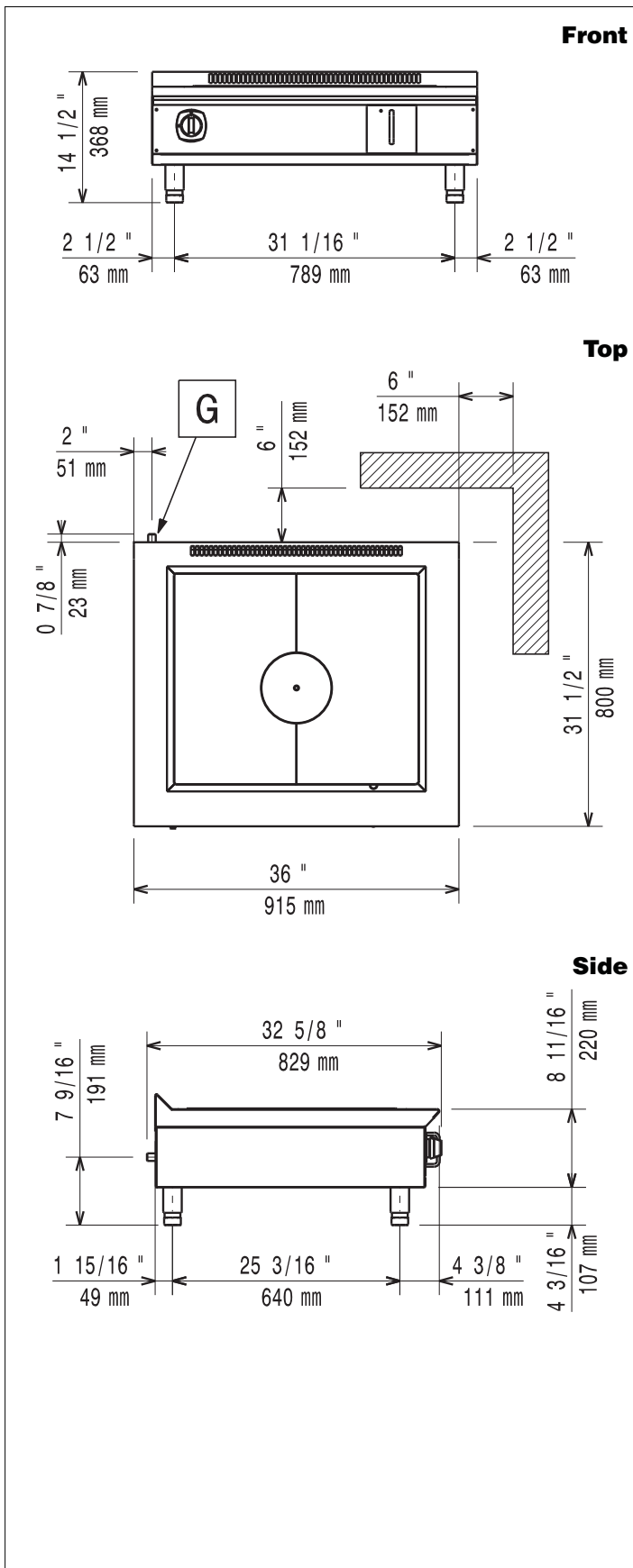

### Gas

Gas power:	27000 Btu/hr (8 kW)
Gas inlet:	3/4" NPT
Natural gas pressure:	3" w.c. (7 mbar)
Propane gas pressure:	7" w.c. (18 mbar)

### Key Information

Solid top usable surface (width):	27 3/16" (690 mm)
Solid top usable surface (depth):	23 1/4" (590 mm)
External dimensions, width	36 1/32" (915 mm)
External dimensions, depth	31 1/2" (800 mm)
External dimensions, height	14 5/8" (372 mm)
Net weight:	146 lbs (66 kg)
Shipping width:	38 9/16" (979 mm)
Shipping depth:	36 1/16" (916 mm)
Shipping height:	25 1/2" (648 mm)
Shipping weight:	176 lbs (80 kg)
Shipping volume:	20.52 ft <sup>3</sup> (0.58 m <sup>3</sup> )

\* The rear and side clearances shown on the diagram indicate the minimum distances recommended from the appliance to combustible surfaces.