



# Electrolux

## EMPower Gas Charbroiler Top 36"

ITEM # \_\_\_\_\_

MODEL # \_\_\_\_\_

NAME # \_\_\_\_\_

SIS # \_\_\_\_\_

AIA # \_\_\_\_\_

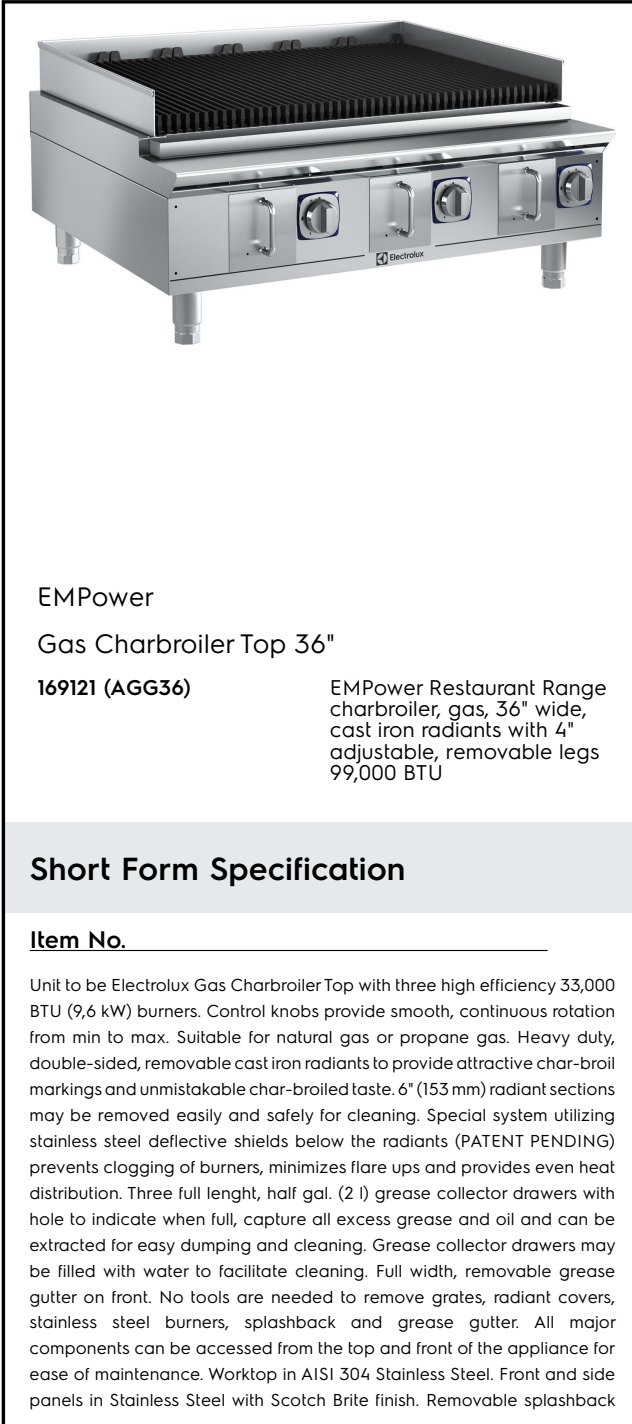

EMPower  
Gas Charbroiler Top 36"

169121 (AGG36)

EMPower Restaurant Range  
charbroiler, gas, 36" wide,  
cast iron radiants with 4"  
adjustable, removable legs  
99,000 BTU

### Short Form Specification

**Item No.** \_\_\_\_\_

Unit to be Electrolux Gas Charbroiler Top with three high efficiency 33,000 BTU (9,6 kW) burners. Control knobs provide smooth, continuous rotation from min to max. Suitable for natural gas or propane gas. Heavy duty, double-sided, removable cast iron radiants to provide attractive char-broil markings and unmistakable char-broiled taste. 6" (153 mm) radiant sections may be removed easily and safely for cleaning. Special system utilizing stainless steel deflective shields below the radiants (PATENT PENDING) prevents clogging of burners, minimizes flare ups and provides even heat distribution. Three full length, half gal. (2 l) grease collector drawers with hole to indicate when full, capture all excess grease and oil and can be extracted for easy dumping and cleaning. Grease collector drawers may be filled with water to facilitate cleaning. Full width, removable grease gutter on front. No tools are needed to remove grates, radiant covers, stainless steel burners, splashback and grease gutter. All major components can be accessed from the top and front of the appliance for ease of maintenance. Worktop in AISI 304 Stainless Steel. Front and side panels in Stainless Steel with Scotch Brite finish. Removable splashback

may be easily disassembled for cleaning. Special heavy duty chrome plated knobs for durability and easy cleaning. The configuration of bezels and knobs provides high level of protection against water infiltrations. Right-angled side edges to allow flush fitting joints between units. Supplied with 4" (102mm) height adjustable, removable legs. Unit may be installed on refrigerated base or open cupboard.

APPROVAL: \_\_\_\_\_



Electrolux

EMPower  
Gas Charbroiler Top 36"



### Main Features

- Two high efficiency gas 33,000 BTU (9,6 kW) burners.
- Burners with optimized combustion and protected pilot light.
- Flame failure device to protect against accidental extinguishing of the flame.
- Control knobs provide smooth, continuous rotation from min to max power level.
- Heavy duty, double-sided, removable cast iron radiants to provide attractive char-broil markings and unmistakable char-broiled taste.
- 6" (153 mm) radiant sections may be removed easily and safely for cleaning.
- Special system utilizing stainless steel deflective shields below the radiants (PATENT PENDING) prevents clogging of burners, minimizes flare ups and provides even heat distribution.
- Three full length, half gal. (2 l) grease collector drawers with hole to indicate when full, captures all excess grease and oil and can be extracted for easy dumping and cleaning.
- Grease collector drawer may be filled with water to facilitate cleaning.
- Full width, removable grease gutter on front.
- No tools are needed to remove grates, radiant covers, stainless steel burner, splashback and grease gutter.
- Removable splashback may be easily disassembled for cleaning.
- All major components can be accessed from the top and front of the appliance for ease of maintenance.
- Front and side panels in Stainless Steel with Scotch Brite finish.
- Special heavy duty chrome plated knobs for durability and easy cleaning.
- The configuration of bezels and knobs provides high level of protection against water infiltrations.
- Right-angled side edges to allow flush fitting joints between units, eliminating gaps and possible dirt traps.
- Provided with kit for side-by-side connection between units for minimizing gaps and possible dirt traps.
- Supplied with 4" (102mm) height adjustable, removable legs.
- Unit may be installed on refrigerated base by removing the legs and inserting the special pins (optional accessory).
- Unit may be installed on open cupboard by removing the legs and inserting the screws provided as standard with the open cupboards.
- Included Accessories: propane converter kit, pressure regulator and main shut off valve.
- In compliance with ETL Certification (UL & NSF).

### Construction

- Worktop in 304 AISI stainless steel.

### Optional Accessories

- 4 Pins Kit, for top equipment on refrigerated base PNC 169048
- - NOT TRANSLATED - PNC 169082
- Back shelf for wall installation, 36"unit PNC 169099

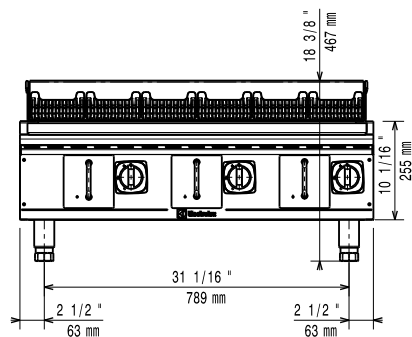
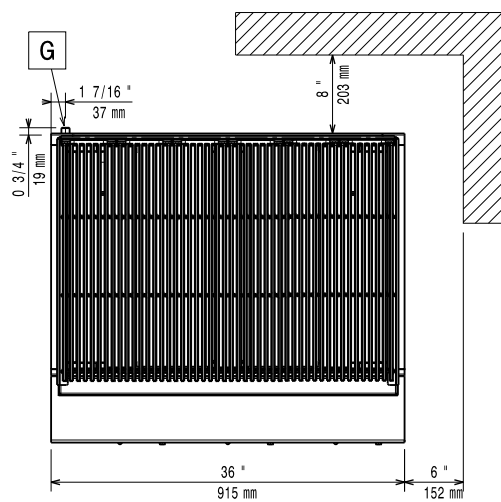
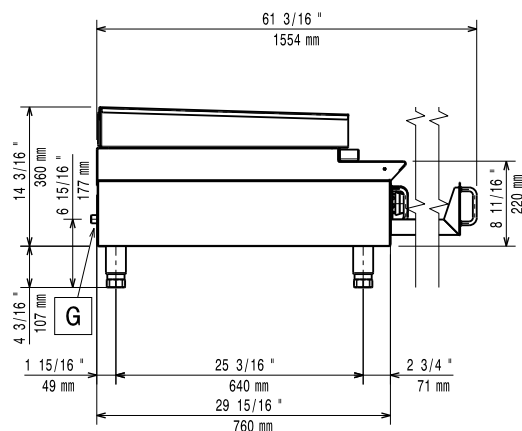
**Front**

**Top**

**G = Gas connection**
**Side**

**Gas**
**Gas Power:**
**169121 (AGG36)**

99000 Btu/hr (28.9 kW)

**Gas Inlet:**

3/4"

**Key Information:**
**External dimensions, Width:** 36 1/32" (915 mm)

**External dimensions, Depth:** 31 1/2" (800 mm)

**External dimensions, Height:** 18 3/8" (467 mm)

**Net weight:** 190 lbs (86 kg)

**Shipping width:** 36 1/16" (916 mm)

**Shipping depth:** 38 9/16" (979 mm)

**Shipping height:** 27 1/16" (688 mm)

**Shipping weight:** 214 lbs (97 kg)

**Shipping volume:** 21.79 ft<sup>3</sup> (0.62 m<sup>3</sup>)

\*The rear and side clearances shown on the diagram indicate the minimum distances recommended from the appliance to combustable surfaces.