



Electrolux

air-o-convect Touchline
air-o-convect TOUCHLINE
Boilerless Combi Oven 62 (electric)

ITEM # _____

MODEL # _____

NAME # _____

SIS # _____

AIA # _____



Electrolux

air-o-convect TOUCHLINE Boilerless Combi Oven 62 (electric)

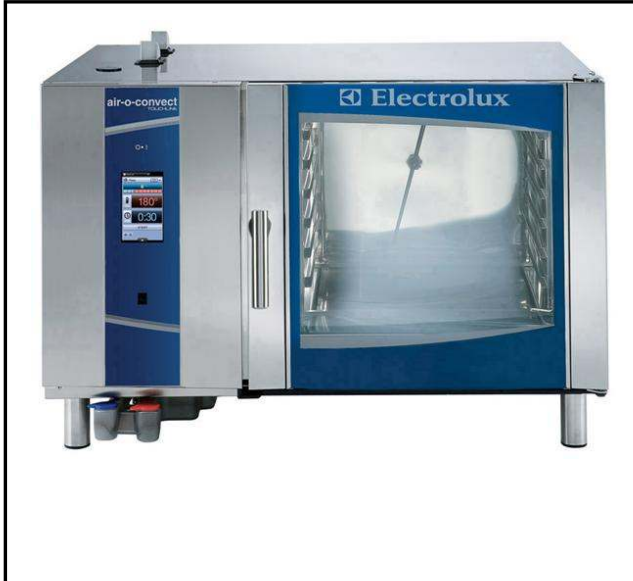

air-o-convect Touchline

air-o-convect TOUCHLINE Boilerless
Combi Oven 62 (electric)

266281 (AOS062EKM1) air-o-convect Touchline
Boilerless Combi Oven 62
208V/3ph/60Hz

Short Form Specification

Item No. _____

Unit to be Electrolux TOUCHLINE air-o-convect Boilerless Combi Oven (electric).
 air-o-convect performs all of the functions of a convection oven and has a boilerless steaming capabilities to add and retain moisture for high quality, consistent cooking cycles. Cooking modes include a convection (hot air) cycle 77 °F-572 °F (25°C-300° C) with an automatic moisture control function with 11 settings from zero to high moisture, double step cooking process, automatic pre-heating, a hold function and automatic rapid cooling. All 304 stainless steel construction, seamless hygienic cooking chamber with all rounded corners. Double thermo-glazed door with open frame construction for cool outside door panel. IPX5 (NEMA 4) spray water protection certification.
 air-o-clean™ automatic and built-in self cleaning system.
 Covered by Electrolux Platinum Star® Service Program, two-year parts and one-year labor warranty, installation start-up and performance checkup after one year from installation.

Main Features

- Dry hot convection cycle max 572°F (max 300°C) ideal for low humidity cooking.
- Automatic moistener (11 settings) for boiler-less steam generation.
 - 0 = no additional moisture (browning, au gratin, baking, pre-cooked food)
 - 1-2 = low moisture (small portions of meat and fish)
 - 3-4 = medium low moisture (large pieces of meat, reheating, roasted chicken and proving)
 - 5-6 = medium moisture (roasted vegetable and first step of roasted meat & fish)
 - 7-8 = medium-high moisture (stewed vegetables)
 - 9-10 = high moisture (poached meat and jacket potatoes)
- Core temperature probe.
- Hold function for keeping food warm at the end of a cycle.
- Automatic and manual rapid cooling activation when going from a higher to a lower cavity temperature.
- air-o-clean™ automatic and built-in self cleaning system (4 automatic) with "Green" functions to save energy, water and rinse aid.
- MultiTimer function to manage a sequence of up to 14 different cooking cycles, improving flexibility and ensuring excellent cooking results. Can be saved up to 70 MultiTimers Programs.
- USB connection: to download HACCP and FSC data, upload the recipes and interface setting.
- Programs mode: a maximum of 1000 recipes can be stored in the oven's memory, to replicate the same results at any time. The recipes can be grouped in up to 16 different categories to help organize the menu. Possible to save programs with up to 16-phases (steps) each.
- air-o-flow: fresh air from the outside is directed to the bi-functional fan, becomes pre-heated and then pushed into the cooking chamber to guarantee an even cooking process.
- Fan speeds: full, half speed and pulse. Full speed active as default. Half speed ideal for delicate cooking such as baking. Pulse ideal for low weight loss and for keeping food warm at the end of the cooking cycle.
- Sous-vide USB probe to ensure excellent cooking results even with vacuum-packed products (optional accessory).
- Make-it-mine feature to allow user to personalize all user main interfaces in the "Setting" mode and block editing and deleting of stored programs.
- Supplied with n.1 tray rack, 2 1/2" 65mm pitch.
- Electrolux Platinum Star® Service package included:
 - 2-year parts, 1-year labor warranty
 - Start-up installation check
 - Equipment check-up after 12 months from installation.
- ETL safety approved, complies with UL 197 and CSA 22.2 listings.
- ETL sanitation approved, complies with NSF/ANSI 2 listing.



APPROVAL: _____



Construction

- IPX 5 spray water protection certification for easy cleaning.
- 304 AISI stainless steel construction throughout.
- Seamless hygienic cooking chamber with all rounded corners for easy cleaning.
- Double thermo-glazed door with open frame construction, for cool outside door panel. Swing hinged easy-release inner glass on door for easy cleaning.
- Swing hinged front panel for easy service access to main components.

- USB Probe for sous-vide cooking (only for Touchline oven) PNC 922281
- Kit flaged feet PNC 922320
- Kit universal skewer rack and 6 short skewers for ovens (TANDOOR) PNC 922325
- Universal skewer pan for ovens (TANDOOR) PNC 922326
- 6 short (14") skewers for ovens (TANDOOR) PNC 922328
- Fat collection tray for ovens (1.5") PNC 922329
- NPT adaptor 1 1/4" gas for ovens PNC 922332
- Smoker for ovens PNC 922338
- Kit check valve PNC 922347

Included Accessories

- 3 of Single 304 stainless steel full-size grid (21"x26") PNC 922076

Optional Accessories

- Automatic water softener for ovens PNC 921305
- Resin sanitizer for water softener PNC 921306
- Wheel kit for base for 61, 62, 101 and 102 oven bases PNC 922003
- Kit - 4 adjustable feet for 61, 62, 101, 102 ovens PNC 922012
- Pair of half size oven racks, type 304 stainless steel PNC 922017
- Chicken racks, pair (2) (fits 8 chickens per rack) PNC 922036
- Tray support for 62 and 102 oven bases PNC 922041
- Trolley for roll-in rack for 62 and 102 oven PNC 922042
- Slide-in rack support with handle for 62 and 102 oven PNC 922047
- Open base with rack guides for air-o-steam 102 PNC 922063
- Single 304 stainless steel full-size grid (21"x26") PNC 922076
- GN 1/1 (12" x 20") tray made of aluminium alloy with no-stick coating, 3/4" (20 mm) deep PNC 922090
- GN 1/1 (12" x 20") tray made of aluminium alloy with no-stick coating, 1 1/2" (40 mm) deep PNC 922091
- GN 1/1 (12" x 20") tray made of aluminium alloy with no-stick coating, 2 1/2" (65 mm) deep PNC 922092
- Kit to connect external rinse aid and detergent tank for 61, 62, 101, and 102 ovens PNC 922169
- External side spray unit (needs to be mounted outside and includes support for mounting to oven) PNC 922171
- Single 304 stainless steel full-size grid (21"x26") PNC 922175
- Fat filter for 61 and 62 oven PNC 922177
- Open base with rack guides for 62 and 102 oven PNC 922198
- Basket for detergent tank (wall mounted) PNC 922209
- GN 1/1 (12" x 20") frying griddle, made of aluminium alloy with no-stick coating PNC 922215
- Pair of frying baskets PNC 922239
- Control panel filter for 62 and 102 oven PNC 922247
- Double-click closing catch for oven door PNC 922265
- Grid for whole chicken 1/1GN (8 per grid - 1,2kg each) PNC 922266
- Stacking kit: 62 on top of 62 or 102 electric oven PNC 922267
- 6 rack cassette (wheel kit not included) for 62 oven (standard pitch) PNC 922269
- 5 rack cassette (wheel kit not included) for 62 oven (increased pitch) PNC 922270
- Heat shield for 62 oven PNC 922271
- Electronic Board for HACCP through PC Network, for air-o-steam and air-o-convect Ovens PNC 922275



Electrolux

air-o-convect Touchline air-o-convect TOUCHLINE Boilerless Combi Oven 62 (electric)

Front

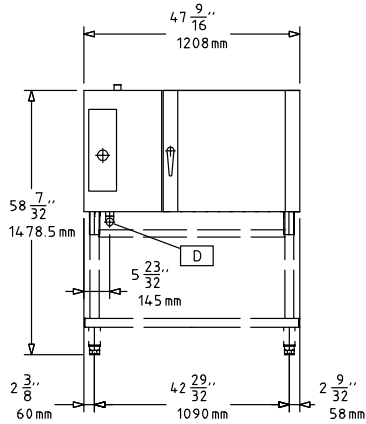

Top

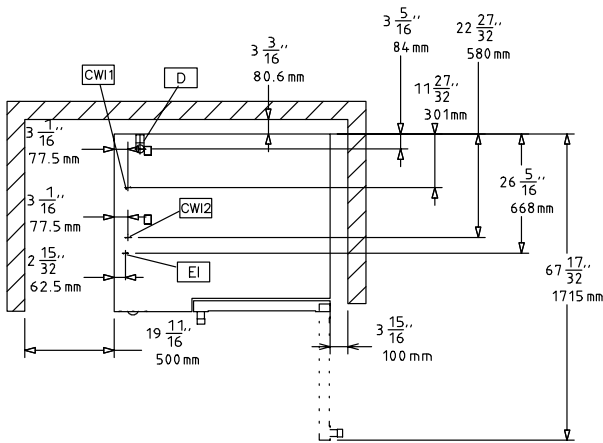

- CWI** = Cold Water inlet
- D** = Drain
- EI** = Electrical connection

Side

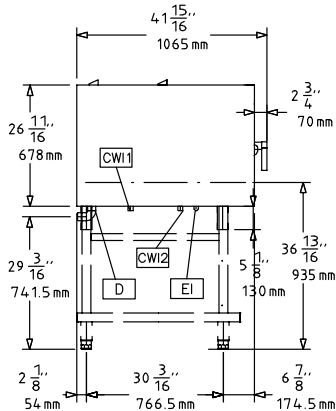

Electric

Supply voltage:

266281 (AOS062EKM1) 208 V/3 ph/60 Hz

Amps:

58 A

Total Watts:

21 kW

Circuit breaker required

Water:

Water inlet "CW" connection:

3/4"

Total hardness:

5-50 ppm

Pressure:

22-65 psi (1.5-4.5 bar)

Drain "D":

1 1/4"

Electrolux recommends the use of treated water, based on testing of specific water conditions.

Please refer to user manual for detailed water quality information.

Installation:

Clearance:

2" (5cm) rear and right hand sides.

Suggested clearance for service access:

20" (50cm) left hand side.

Capacity:

Sheet pans:

6 - 18"x 26"

Steam pans:

12 - 12"x 20"

Half size sheet pans:

12 - 13"x 18"

Max load capacity:

106 lbs. (48 kg)

Key Information:

Net weight:

353 lbs (160 kg)

Shipping width:

46 7/8" (1190 mm)

Shipping depth:

50 13/16" (1290 mm)

Shipping height:

44 1/2" (1130 mm)

Shipping weight:

406 lbs (184 kg)

Shipping volume:

61.25 ft³ (1.73 m³)

air-o-convect Touchline
air-o-convect TOUCHLINE Boilerless Combi Oven 62 (electric)

The company reserves the right to make modifications to the products without prior notice. All information correct at time of printing.