



Electrolux

air-o-convect Touchline
air-o-convect TOUCHLINE
Boilerless Combi Oven 61 (gas)

ITEM # _____
MODEL # _____
NAME # _____
SIS # _____
AIA # _____



Electrolux

air-o-convect TOUCHLINE Boilerless Combi Oven 61 (gas)



air-o-convect Touchline

air-o-convect TOUCHLINE Boilerless
Combi Oven 61 (gas)

266750 (AOS061GKP1)

air-o-convect Touchline
Boilerless Combi Oven 61
120V/1ph/60Hz

Short Form Specification

Item No. _____

Unit to be Electrolux air-o-convect TOUCHLINE Boilerless Combi Oven (gas). air-o-convect performs all of the functions of a convection oven and has a boilerless steaming capabilities to add and retain moisture for high quality, consistent cooking cycles. Cooking modes include a convection (hot air) cycle 77 °F-572 °F (25°C-300° C) with an automatic moisture control function with 11 settings from zero to high moisture, double step cooking process, automatic pre-heating, a hold function and automatic rapid cooling. All 304 stainless steel construction, seamless hygienic cooking chamber with all rounded corners. Double thermo-glazed door with open frame construction for cool outside door panel. IPX5 (NEMA 4) spray water protection certification. air-o-clean™ automatic and built-in self cleaning system.

Covered by Electrolux Platinum Star® Service Program, two-year parts and one-year labor warranty, installation start-up and performance checkup after one year from installation.

Main Features

- Dry hot convection cycle max 572°F (max 300°C) ideal for low humidity cooking.
- Automatic moistener (11 settings) for boiler-less steam generation.
 - 0 = no additional moisture (browning, au gratin, baking, pre-cooked food)
 - 1-2 = low moisture (small portions of meat and fish)
 - 3-4 = medium low moisture (large pieces of meat, reheating, roasted chicken and proving)
 - 5-6 = medium moisture (roasted vegetable and first step of roasted meat & fish)
 - 7-8 = medium-high moisture (stewed vegetables)
 - 9-10 = high moisture (poached meat and jacket potatoes)
- Programs mode: a maximum of 1000 recipes can be stored in the oven's memory, to replicate the same results at any time. The recipes can be grouped in up to 16 different categories to help organize the menu. Possible to save programs with up to 16-phases (steps) each.
- MultiTimer function to manage a sequence of up to 14 different cooking cycles, improving flexibility and ensuring excellent cooking results. Can be saved up to 70 MultiTimers Programs.
- air-o-flow: fresh air from the outside is directed to the bi-functional fan, becomes pre-heated and then pushed into the cooking chamber to guarantee an even cooking process.
- Core temperature probe.
- Fan speeds: full, half speed and pulse. Full speed active as default. Half speed ideal for delicate cooking such as baking. Pulse ideal for low weight loss and for keeping food warm at the end of the cooking cycle.
- USB connection: to download HACCP and FSC data, upload the recipes and interface setting.
- Sous-vide USB probe to ensure excellent cooking results even with vacuum-packed products (optional accessory).
- air-o-clean™ automatic and built-in self cleaning system (4 automatic) with "Green" functions to save energy, water and rinse aid.
- Hold function for keeping food warm at the end of a cycle.
- Automatic and manual rapid cooling activation when going from a higher to a lower cavity temperature.
- Make-it-mine feature to allow user to personalize all user main interfaces in the "Setting" mode and block editing and deleting of stored programs.
- Supplied with n.1 tray rack, 2 1/2" 65mm pitch.
- Electrolux Platinum Star® Service package included:
 - 2-year parts, 1-year labor warranty
 - Start-up installation check
 - Equipment check-up after 12 months from installation.
- ETL safety approved, complies with UL 197 and CSA 22.2 listings.
- ETL sanitation approved, complies with NSF/ANSI 2 listing.



APPROVAL: _____

Electrolux Professional, Inc.

www.electroluxusa.com/professional

10200 David Taylor Drive, Charlotte, NC 28262 • Telephone Number: 866-449-4200 • Fax Number: 704-547-7401



Electrolux

air-o-convect Touchline air-o-convect TOUCHLINE Boilerless Combi Oven 61 (gas)

Included Accessories

- 3 of Single 304 stainless steel grid (12"x20") PNC 922062

Optional Accessories

- Flue condenser for hood for 6 GN 1/1 and 10 GN 1/1 gas ovens. The flue condenser is mandatory on installations with ventilation hoods (640791 - 640792) PNC 640413 ☐
- Exhaust hood without fan for 6&10 1/1GN ovens. It is mandatory to use the flue condenser (640413) on installation with gas ovens PNC 640791 ☐
- Exhaust hood with fan for 6&10x1/1 GN ovens. It is mandatory to use the flue condenser (640413) on installation with gas ovens PNC 640792 ☐
- Automatic water softener for ovens PNC 921305 ☐
- Resin sanitizer for water softener PNC 921306 ☐
- Wheel kit for base for 61, 62, 101 and 102 oven bases PNC 922003 ☐
- Trolley for rack cassette for 61 and 101 oven PNC 922004 ☐
- 6 rack cassette (wheel kit included) for 61 oven (standard pitch) PNC 922005 ☐
- 5 rack cassette (wheel kit included) for 61 oven (increased pitch) PNC 922008 ☐
- Kit - 4 adjustable feet for 61, 62, 101, 102 ovens PNC 922012 ☐
- Pair of half size oven racks, type 304 stainless steel PNC 922017 ☐
- Tray support for 61 and 101 oven bases PNC 922021 ☐
- Chicken racks, pair (2) (fits 8 chickens per rack) PNC 922036 ☐
- Pastry Rack (400mm x 600mm) for 6 Hotel or Steam pans air-o-system PNC 922065 ☐
- Wheels and Hinges kit for 6 and 10 oven PNC 922073 ☐
- Stainless steel 304 grids (GN ½) with spikes, fits 4PNC 922086 ☐ chickens
- Base support for air-o-system 6 GN 1/1 with hood PNC 922087 ☐
- GN 1/1 (12" x 20") tray made of aluminium alloy with no-stick coating, 3/4" (20 mm) deep PNC 922090 ☐
- GN 1/1 (12" x 20") tray made of aluminium alloy with no-stick coating, 1 1/2" (40 mm) deep PNC 922091 ☐
- GN 1/1 (12" x 20") tray made of aluminium alloy with no-stick coating, 2 1/2" (65 mm) deep PNC 922092 ☐
- Kit to connect external rinse aid and detergent tank for 61, 62, 101, and 102 ovens PNC 922169 ☐
- External side spray unit (needs to be mounted outside and includes support for mounting to oven) PNC 922171 ☐
- Fat filter for 61 and 62 oven PNC 922177 ☐
- 16" x 24" (400 x 600mm) Baguette tray, made of perforated aluminium, silicon coated PNC 922189 ☐
- 16" x 24" (400 x 600mm) Perforated baking tray, made of perforated aluminium PNC 922190 ☐
- Baking tray, made of aluminium 16" x 24" (400 x 600 mm) PNC 922191 ☐
- Open base with rack guides for 61 and 101 oven PNC 922195 ☐
- Holder for detergent tank on open base PNC 922212 ☐
- GN 1/1 (12" x 20") frying griddle, made of aluminium alloy with no-stick coating PNC 922215 ☐
- Flue condensor for gas ovens PNC 922235 ☐
- Pair of frying baskets PNC 922239 ☐
- Heat shield for 61 on top of 61 oven stacking kit PNC 922244 ☐
- Heat shield for 61 on top of 101 oven stacking kit PNC 922245 ☐
- Control panel filter for 61 and 101 oven PNC 922246 ☐
- Heat shield for 61 oven PNC 922250 ☐

- Grid for whole chicken 1/1GN (8 per grid - 1,2kg each) PNC 922266 ☐
- Electronic Board for HACCP through PC Network, for air-o-steam and air-o-convect Ovens PNC 922275 ☐
- Kit to convert from natural gas to LPG PNC 922277 ☐
- USB Probe for sous-vide cooking (only for Touchline oven) PNC 922281 ☐
- Kit bakery rack for 61 oven for bakery trays 600x400mm PNC 922282 ☐
- Drain kit (diameter 2") for 61, 62, 101, 102 ovens PNC 922283 ☐
- Pastry runners (400x600 mm) for 6 & 10 GN1/1 oven bases PNC 922286 ☐
- Trolley for grease collection with specific grease drip tray for 101 oven (should be ordered with 1 each PNC 922099) PNC 922287 ☐
- Baguette tray (holds 4), made of perforated aluminium, silicon coated, GN1/1 (12" x 20") PNC 922288 ☐
- Oven grill made of aluminium alloy with no-stick coating PNC 922289 ☐
- GN 1/1 (12" x 20") egg fryer grid, made of aluminium alloy with no-stick coating. Fits 8 eggs PNC 922290 ☐
- Conversion kit from natural gas to LPG for 61 ovens PNC 922293 ☐
- GN 1/1 (12" x 20") baking sheet, made of aluminium alloy with no-stick coating PNC 922299 ☐
- Kit flaged feet PNC 922320 ☐
- Fat collection tray PNC 922321 ☐
- Trolley for slide-in rack 10x1/1GN PNC 922323 ☐
- Kit universal skewer rack and 4 long skewers for ovens (TANDOOR) PNC 922324 ☐
- Universal skewer pan for ovens (TANDOOR) PNC 922326 ☐
- 4 long (24") skewers for ovens (TANDOOR) PNC 922327 ☐
- Fat collection tray for ovens (1.5") PNC 922329 ☐
- Riser for stacked ovens (61 on 61 ovens) with feet (10" height) PNC 922330 ☐
- Riser for stacked ovens (61 on 61 ovens) with wheels (10" height) PNC 922331 ☐
- NPT adaptor 1 1/4" gas for ovens PNC 922332 ☐
- Wheels for stacked ovens (61 on 61 ovens, or 61 on 101 ovens) PNC 922333 ☐
- Smoker for ovens PNC 922338 ☐
- Water filter for ovens - 2 membranes PNC 922342 ☐
- External reverse osmosis filter for ovens - 2 membranes PNC 922343 ☐
- - NOT TRANSLATED - PNC 922346 ☐
- Kit check valve PNC 922347 ☐



Electrolux

air-o-convect Touchline air-o-convect TOUCHLINE Boilerless Combi Oven 61 (gas)

Front

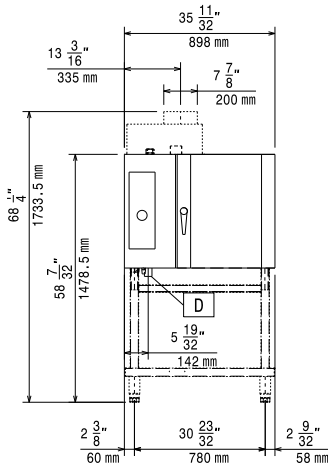

Top

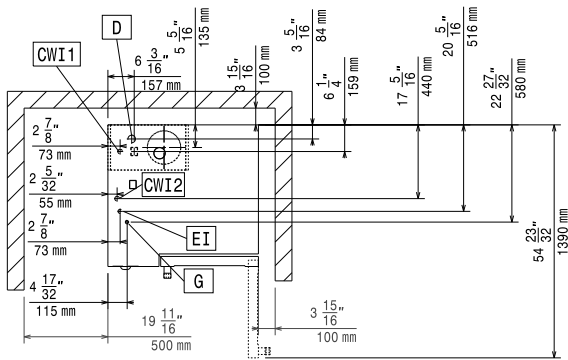

- CWI** = Cold Water inlet
- D** = Drain
- EI** = Electrical connection
- G** = Gas connection

Side

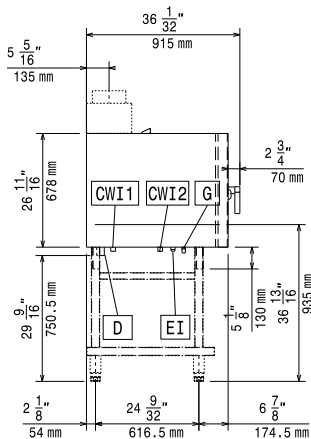

Electric

Supply voltage:

266750 (AOS061GKP1) 120 V/1 ph/60 Hz

Amps:

4 A

Circuit breaker required

Gas

Gas Power:

40982 Btu/hr (12 kW)

ISO 7/1 gas connection diameter:

1/2" MNPT

Max rated thermal load:

Natural gas:

Total thermal load:

40982 BTU (12 kW)

LPG:

Total thermal load:

40982 BTU (12 kW)

Water:

Water inlet "CW" connection:

3/4"

Total hardness:

5-50 ppm

Pressure:

15-36 psi (1-2.5 bar)

Drain "D":

1"1/4

Electrolux recommends the use of treated water, based on testing of specific water conditions.

Please refer to user manual for detailed water quality information.

Installation:

Clearance:

2" (5cm) rear and right hand sides.

Suggested clearance for service access:

20" (50cm) left hand side.

Capacity:

Sheet pans:

6 - 12"x 20"

Max load capacity:

106 lbs. (48 kg)

Key Information:

Net weight:

331 lbs (150 kg)

Shipping width:

37 5/8" (955 mm)

Shipping depth:

38 3/4" (985 mm)

Shipping height:

41 15/16" (1065 mm)

Shipping weight:

373 lbs (169 kg)

Shipping volume:

35.37 ft³ (1 m³)

air-o-convect Touchline
air-o-convect TOUCHLINE Boilerless Combi Oven 61 (gas)

The company reserves the right to make modifications to the products without prior notice. All information correct at time of printing.

2014.0704