



**Electrolux**

air-o-steam  
air-o-steam TOUCHLINE  
Electric Combi Oven 202

ITEM # \_\_\_\_\_

MODEL # \_\_\_\_\_

NAME # \_\_\_\_\_

SIS # \_\_\_\_\_

AIA # \_\_\_\_\_



Electrolux

air-o-steam TOUCHLINE Electric Combi Oven 202

air-o-steam



air-o-steam

air-o-steam TOUCHLINE Electric  
Combi Oven 202

**267285 (AOS202ETM1)**

EI Combi TOUCHLINE Oven  
202 – 208V/3ph/60Hz - 134A

### Short Form Specification

**Item No.** \_\_\_\_\_

Unit to be Electrolux air-o-steam® Combi TOUCHLINE Oven. The air-o-steam® features three cooking modes – Automatic, Programs and Manual. Large touch-screen display for both set and actual values of humidity and temperature in cooking chamber during cooking. Three automatic modes: Low Temperature Cooking cycle (LTC), reheating cycle and proofing cycle. Traditional cooking modes - steam (max. 266 °F - 130°C), hot convected air (max. 572 °F - 300°C) and combi-mode (max. 482°F - 250°C). Each cooking mode operates under Lambda-sensor driven air-o-clima™: automatic and constant real humidity control. 6-point multi-sensor for core temperature controlled cooking cycles. All 304 stainless-steel construction, seamless hygienic cooking chamber with all rounded corners. Double thermo-glazed door with open frame construction for cool outside door panel. Halogen cooking chamber lighting. IPX-5 spray water protection certification. Retractable spray hose included as standard. USB connection. air-o-clean™, automatic and built-in self-cleaning system. Food Safe control to automatically monitor and validate the cooking process according to HACCP standards. HACCP management available upon request. Green functions to save energy, water and rinse aid. Half day chef training included. Covered by Electrolux Platinum Star® Service Program two-year parts and one-year labor warranty, installation start-up and performance checkup after one year from installation.



**APPROVAL:** \_\_\_\_\_

### Main Features

- Manual mode: traditional cooking style by manually selecting the parameters. Traditional cooking cycles available:
  - Dry, hot convection cycle (max. 212 °F / max 300 °C): ideal for low humidity cooking such as dehydration, baking and grilling.
  - Low temperature steam cycle (max. 212 °F / 100 °C): ideal for sous-vide (vacuum packed), rethermalization and delicate steam cooking.
  - Steam cycle (212 °F / 100 °C): ideal for traditionally steaming products such as seafood and vegetables.
  - High temperature steam (max. 266 °F / max. 130 °C): ideal for steaming frozen products and vegetables.
  - Combination cycle (max. 482 °F / max. 250 °C): combines convected heat and steam to obtain a humidity controlled cooking environment, accelerating the cooking process, while guaranteeing perfect textures and reducing weight loss.

Possible to set up to 16-phases (steps).

- Programs mode: a maximum of 1000 recipes can be stored in the oven's memory, to replicate the same results at any time. The recipes can be grouped in up to 16 different categories to help organize the menu. Possible to save programs with up to 16-phases (steps) each.
- Automatic mode: by choosing family and food type, the oven automatically selects the appropriate cooking climate, temperature and time. A maximum of 60 personalized preset can be saved per family. Three special automatic cycles available:
  - Low Temperature Cooking cycle (LTC) PATENTED: ideal for large cuts of meat, to minimize weight loss and maximize food quality.
  - Regenerating cycle: efficient humidity management for fast and easy rethermalization, both on plate as well as on tray.
  - Proofing cycle: uses the air-o-clima™ function manages temperature and humidity to create the perfect proofing conditions.
- air-o-clima™ PATENTED: Lambda sensor controlled, automatic humidity adjustment of cooking environment based on settings for perfect textures and repeatability.
- MultiTimer function to manage a sequence of up to 14 different cooking cycles, improving flexibility and ensuring excellent cooking results. Can be saved up to 70 MultiTimers Programs.
- air-o-flow: fresh air from the outside is directed to the bi-functional fan, becomes pre-heated and then pushed into the cooking chamber to guarantee an even cooking process.
- 6-point multi sensor core temperature probe for maximum precision and food safety.
- Fan speeds: full, half speed and pulse. Full speed active as default. Half speed ideal for delicate cooking such as baking. Pulse ideal for low weight loss and for keeping food warm at the end of the cooking cycle.
- Food Safe Control (FSC) PATENTED monitors the cooking process to comply with HACCP standards. HACCP management to record cooking procedure available upon request.
- USB connection: to download HACCP and FSC data, upload the recipes and interface setting.
- Sous-vide USB probe to ensure excellent cooking results even with vacuum-packed products (optional accessory).

Electrolux Professional, Inc.

[www.electroluxusa.com/professional](http://www.electroluxusa.com/professional)

10200 David Taylor Drive, Charlotte, NC 28262 • Telephone Number: 866-449-4200 • Fax Number: 704-547-7401



- air-o-clean™ automatic and built-in self cleaning system (4 automatic) with "Green" functions to save energy, water and rinse aid.
- Guided descaling function to guide operator during boiler descaling phase (from "Setting" mode).
- Supplied with n.1 roll-in tray rack, 2 1/2" 63mm pitch and door shield.
- Electrolux Platinum Star® Service package included:
  - 2-year parts, 1-year labor warranty
  - Start-up installation check
  - Equipment check-up after 12 months from installation.
- ETL safety approved, complies with UL 197 and CSA 22.2 listings.
- ETL sanitation approved, complies with NSF/ANSI 2 listing.

### Construction

- 304 AISI stainless steel construction throughout.
- Double thermo-glazed door with open frame construction, for cool outside door panel. Swing hinged easy-release inner glass on door for easy cleaning.
- IPX 5 spray water protection certification for easy cleaning.
- Seamless hygienic cooking chamber with all rounded corners for easy cleaning.
- Swing hinged front panel for easy service access to main components.

### Included Accessories

- 1 of Trolley tray rack (10), for 202 oven (standard pitch) PNC 922044
- 10 of Single 304 stainless steel full-size grid (21"x26") PNC 922076
- 1 of Control panel filter for 202 oven PNC 922249

### Optional Accessories

- Automatic water softener for ovens PNC 921305
- Resin sanitizer for water softener PNC 921306
- Chicken racks, pair (2) (fits 8 chickens per rack) PNC 922036
- Trolley tray rack (10), for 202 oven (standard pitch) PNC 922044
- Trolley tray rack (8), for 202 oven (increased pitch) PNC 922046
- Thermal blanket for 202 trolley racks PNC 922049
- Trolley rack for 202 with 3 1/3" (85 mm) pitch, 92 plates PNC 922055
- Pair of 304 stainless steel full-size grid (21"x26") PNC 922060
- Pastry Trolley (400mm x 600mm) for 20 Full-size sheet pans air-o-system PNC 922069
- GN 1/1 (12" x 20") tray made of aluminium alloy with no-stick coating, 3/4" (20 mm) deep PNC 922090
- GN 1/1 (12" x 20") tray made of aluminium alloy with no-stick coating, 1 1/2" (40 mm) deep PNC 922091
- GN 1/1 (12" x 20") tray made of aluminium alloy with no-stick coating, 2 1/2" (65 mm) deep PNC 922092
- Door shield for 202 oven (pre-heat without trolley) PNC 922095
- External side spray unit (needs to be mounted outside and includes support for mounting to oven) PNC 922171
- Single 304 stainless steel full-size grid (21"x26") PNC 922175
- (2) fat filters for 201 and 202 oven PNC 922179
- 16" x 24" (400 x 600mm) Baguette tray, made of perforated aluminium, silicon coated PNC 922189

- 16" x 24" (400 x 600mm) Perforated baking tray, made of perforated aluminium PNC 922190
- Baking tray, made of aluminium 16" x 24" (400 x 600 mm) PNC 922191
- Basket for detergent tank (wall mounted) PNC 922209
- Pair of frying baskets PNC 922239
- Heat shield for 202 oven PNC 922242
- Grid for whole chicken 1/1GN (8 per grid - 1,2kg each) PNC 922266
- Electronic Board for HACCP through PC Network, for air-o-steam and air-o-convect Ovens PNC 922275
- Adjustable wheels for 201 oven PNC 922280
- USB Probe for sous-vide cooking (only for Touchline oven) PNC 922281
- Baguette tray (holds 4), made of perforated aluminium, silicon coated, GN1/1 (12" x 20") PNC 922288
- Oven grill made of aluminium alloy with no-stick coating PNC 922289
- GN 1/1 (12" x 20") egg fryer grid, made of aluminium alloy with no-stick coating. Fits 8 eggs PNC 922290
- Universal skewer pan for ovens (TANDOOR) PNC 922326
- NPT adaptor 1 1/4" gas for ovens PNC 922332



Electrolux

air-o-steam  
air-o-steam TOUCHLINE  
Electric Combi Oven 202

Front

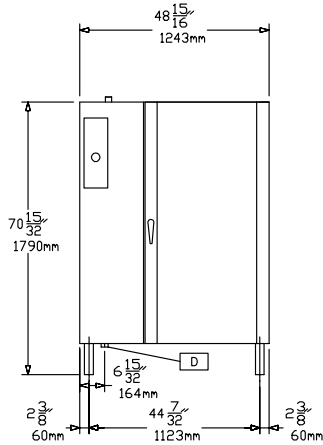

Top

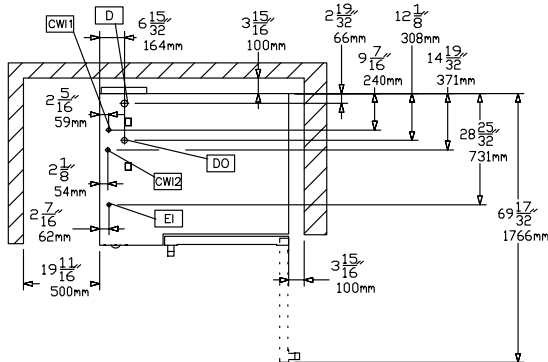

- CW1** = Cold Water inlet
- D** = Drain
- EI** = Electrical connection

Side

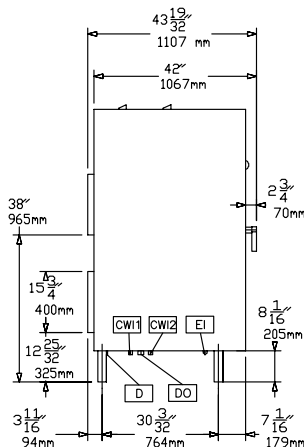

Electric

<b>Supply voltage:</b>	<b>267285 (AOS202ETM1)</b>	208 V/3 ph/60 Hz
<b>Amps:</b>		133
<b>Connected load:</b>		48 kW
<b>Circuit breaker required</b>		

Water:

<b>Water inlet "CW" connection:</b>	3/4"	5-50ppm (boiler/steam – rear connection) less than 400ppm (cleaning/quenching - front connection)
<b>Hardness:</b>		
<b>Water consumption (gal./hr.):</b>	Min: 7.13 Max: 26.42	
<b>Pressure:</b>	22-36 psi (1.5-2.5 bar)	
<b>Drain "D":</b>	2"	
<b>Conductivity:</b>	(50-200 µs/cm)	
<b>Chlorides:</b>	(must be less than 20 ppm)	
<b>PH:</b>	(must be greater than 7)	

*Electrolux recommends the use of treated water, based on testing of specific water conditions.*

*Please refer to user manual for detailed water quality information*

It is obligatory upon the end-user to supply the combi with water that conforms to the specifications attached on the spec sheet. A properly sized system combined with a disciplined filter replacement regimen will ensure the maximum life of the oven.

Installation:

<b>Clearance:</b>	2" rear and right hand sides
<b>Suggested clearance for service access:</b>	20" left hand side.

Capacity:

<b>Sheet pans:</b>	20 - 18" x 26"
<b>Steam pans:</b>	40 - 12" x 20"
<b>Half size sheet pans:</b>	40 - 13" x 18"
<b>GN:</b>	40 - 1/1 containers
<b>GN:</b>	20 - 2/1 containers
<b>Max load capacity:</b>	440 lbs. (200 kg)

Key Information:

<b>Net weight:</b>	893 lbs (405 kg)
<b>Shipping width:</b>	51 3/16" (1300 mm)
<b>Shipping depth:</b>	46 1/16" (1170 mm)
<b>Shipping height:</b>	80 5/16" (2040 mm)
<b>Shipping weight:</b>	959 lbs (435 kg)
<b>Shipping volume:</b>	109.56 ft <sup>3</sup> (3.1 m <sup>3</sup> )

air-o-steam  
air-o-steam TOUCHLINE Electric Combi Oven 202

The company reserves the right to make modifications to the products without prior notice. All information correct at time of printing.