



Electrolux

# air-o-convect air-o-convect Manual Boilerless Combi Oven 101 (gas)

ITEM # \_\_\_\_\_

MODEL # \_\_\_\_\_

NAME # \_\_\_\_\_

SIS # \_\_\_\_\_

AIA # \_\_\_\_\_



## air-o-convect

### air-o-convect Manual Boilerless Combi Oven 101 (gas)

269752 (AOS101GCP1)

air-o-convect Boilerless Combi Oven 101  
120V/1ph/60Hz

## Short Form Specification

### Item No.

Unit to be Electrolux air-o-convect Boilerless Combi Oven (electric).

air-o-convect performs all of the functions of a convection oven and has a boilerless steaming capabilities to add and retain moisture for high quality, consistent cooking cycles. Cooking modes include a convection (hot air) cycle 77 °F-572 °F (25°C-300°C) with an automatic moisture control function with 11 settings from zero to high moisture, double step cooking process, automatic pre-heating, a hold function and automatic rapid cooling. All 304 stainless steel construction, seamless hygienic cooking chamber with all rounded corners. Double thermo-glazed door with open frame construction for cool outside door panel. IPX5 (NEMA 4) spray water protection certification.

air-o-clean™ automatic and built-in self cleaning system.

Covered by Electrolux Platinum Star® Service Program, two-year parts and one-year labor warranty, installation start-up and performance checkup after one year from installation.



APPROVAL: \_\_\_\_\_

## Main Features

- Dry hot convection cycle 77 °F-572 °F (25°C to 300°C) ideal for low humidity baking.
- Automatic moistener (11 settings) for boilerless steam generation.
  - 0 = no additional moisture (air frying, dehydrating, baking, browning)
  - 1-2 = low moisture (roasting, grilling, searing, baking, cookies, cakes, grill cheese)
  - 3-4 = medium low moisture (au gratin vegetables, roasted meat and fish)
  - 5-6 = medium moisture (roasting small portions poultry, meet and fish, casserole, pizza)
  - 7-8 = medium-high moisture (Roasting and backing, large portions of meat, whole: chicken, turkey, ham)
  - 9-10 = high moisture (proofing, low temperature steaming, steam vegetables, rice, pasta, fish, shell fish, bagged product, sous vide, re-thermalization, baking)
- Double step cooking (first phase with moisture, second phase dry for browning).
- Core temperature probe.
- Variable fan speed (radial fan): full speed or pulse ventilation (Hold) for baking and slow cooking.
- Hold function for keeping food warm at the end of a cycle.
- Exhaust valve electronically controlled to extract excess humidity.
- Automatic and manual rapid cooling activation when going from a higher to a lower temperature.
- air-o-clean™ automatic and built-in self cleaning system (4 automatic and 1 semi-automatic cycles).
- Electrolux Platinum Star®; Service package included:
  - 2-year parts, 1-year labor warranty.
  - Start-up installation check.
  - Equipment check-up after 12 months from installation.
- IPX5 – Water Jets protected (Water projected by a nozzle (6.3 mm) against enclosure from any direction shall have no harmful effects.).
- ETL safety approved, complies with UL 197 and CSA 22.2 listings.
- ETL sanitation approved, complies with NSF/ANSI 2 listing.

## Construction

- All 304 stainless steel construction.
- Seamless hygienic cooking chamber with all rounded corners for easy cleaning.
- Double thermo-glazed door with open frame construction, for cool outside door panel. Swing hinged easy-release inner glass on door for easy cleaning.



Electrolux

air-o-convect Manual Boilerless Combi Oven 101 (gas)

Electrolux Professional, Inc.

www.electroluxusa.com/professional

10200 David Taylor Drive, Charlotte, NC 28262 • Telephone Number: 866-449-4200 • Fax Number: 704-547-7401



Electrolux

## air-o-convect air-o-convect Manual Boilerless Combi Oven 101 (gas)

- Swing hinged front panel for easy service access to main components.

\*Electrolux recommends a certified service agent perform equipment install and start-up, and an Electrolux certified chef be hired to train kitchen staff on equipment operation and maintenance.

### Included Accessories

- 5 of Single 304 stainless steel grid (12"x20") PNC 922062

### Optional Accessories

- Wheel kit for base for 61, 62, 101 and 102 oven bases PNC 922003
- Trolley for rack cassette for 61 and 101 oven PNC 922004
- 10 rack cassette for 101 oven (standard pitch) PNC 922006
- 8 rack cassette for 101 oven (increased pitch) PNC 922009
- Thermal blanket for 101 racks PNC 922013
- Mobile banqueting rack for 101 with 2 1/2" (65 mm) pitch, 30 plates (should be ordered with 1 each PNC 922074) PNC 922015
- Tray support, for 61 and 101 oven bases PNC 922021
- Chicken Racks, pair (2) (fits 8 chickens per rack) PNC 922036
- Mobile banqueting rack for 101 with 3 1/3" (85 mm) pitch, 23 plates (should be ordered with 1 each PNC 922074) PNC 922071
- Wheels and Hinges kit for 61 and 101 oven PNC 922073
- Slide-in rack support with handle for 61 and 101 oven PNC 922074
- GN 1/1 (12" x 20") tray made of aluminium alloy with no-stick coating, 3/4" (20 mm) deep PNC 922090
- GN 1/1 (12" x 20") tray made of aluminium alloy with no-stick coating, 1 1/2" (40 mm) deep PNC 922091
- GN 1/1 (12" x 20") tray made of aluminium alloy with no-stick coating, 2 1/2" (65 mm) deep PNC 922092
- Fat filter for 101 and 102 oven PNC 922178
- 16" x 24" (400 x 600mm) Perforated baking tray, made of perforated aluminium PNC 922190
- Baking tray, made of aluminium 16" x 24" (400 x 600 mm) PNC 922191
- Open base with rack guides for 61 and 101 oven PNC 922195
- Heat shield for 61 on top of 101 oven stacking kit PNC 922245
- Heat shield for 101 oven PNC 922251
- Double-click closing catch for oven door PNC 922265
- Trolley for grease collection with specific grease drip tray for 101 oven (should be ordered with 1 each PNC 922099) PNC 922287



Electrolux

# air-o-convect air-o-convect Manual Boilerless Combi Oven 101 (gas)

**Front**

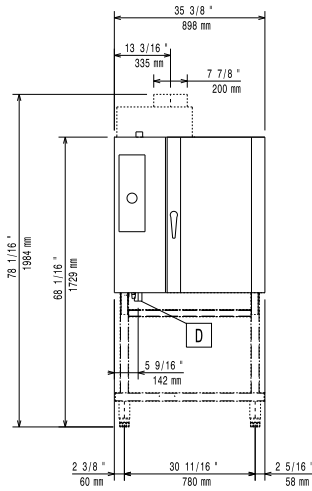

**Top**

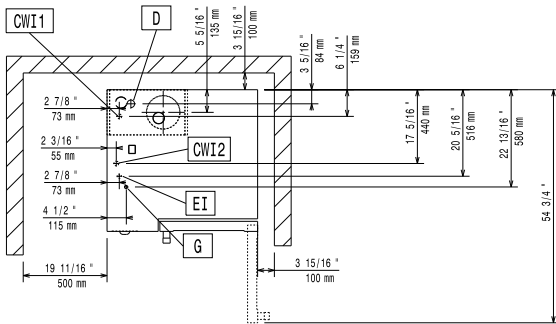

**CWI** = Cold Water inlet                      **G** = Gas connection  
**D** = Drain  
**EI** = Electrical connection

**Side**

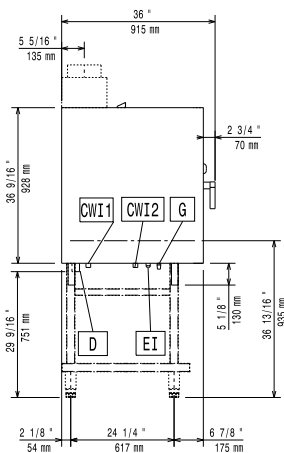

**Electric**

**Supply voltage:**  
 269752(AOS101GCP1)                      120 V/1N ph/60 Hz  
**Connected load:**                              0.5 kW  
**Circuit breaker required**

**Water:**

**Water inlet "CW" connection:**              3/4"  
**Total hardness:**                              5-50 ppm  
**Pressure:**                                        1.5-4.5 bar  
**Drain "D":**                                        1"1/4

*Electrolux recommends the use of treated water, based on testing of specific water conditions.*

*Please refer to user manual for detailed water quality information.*

**Installation:**

**Clearance:**                                        2" (5cm) rear and right hand sides.  
**Suggested clearance for service access:**    20" (50cm) left hand side.

**Capacity:**

**Steam pans:**                                    10 - 12" x 20"  
**Half size sheet pans:**                        10 - 13" x 18"  
**Max load capacity:**                            110 lbs (50 kg)

**Key Information:**

**Shipping volume:**                              1.19 m<sup>3</sup>  
**Net Weight:**                                    368 lbs (167 kg)  
**Shipping Weight:**                            412 lbs (187 kg)  
**Shipping Height:**                              50" (1265mm)  
**Shipping Width:**                              38" (955mm)  
**Shipping Depth:**                              39" (985mm)

air-o-convect  
 air-o-convect Manual Boilerless Combi Oven 101 (gas)

The company reserves the right to make modifications to the products without prior notice. All information correct at time of printing.

2013.04.22