

Electrolux

Pasta Solutions Free-standing, Double-well Pasta Cooker – Electric

ITEM # _____

MODEL # _____

PROJECT NAME # _____

SIS # _____

AIA # _____



Pasta Solutions Free-standing, Double-well Pasta Cooker – Electric

391204 (E9PCEH2MF2) Electric Pasta Cooker
208 V/3p/60z – 56 A

Short Form Specification

Item No. _____

Unit to be Electrolux Double Well Electric Pasta Cooker 391204. The unit is a free-standing, 10.5 gallon, double well Electric Pasta Cooker. The unit shall feature constant water level refill and starch removal during cooking process. IPX 5 water jet protection (NEMA 4 equivalent). The two 10.5 gallon tanks are pressed in AISI 316 stainless steel and features only rounded corners. 5" long, height adjustable legs. The unit to be completely in AISI 304 stainless steel.

Covered by Electrolux Platinum Star® Service Program two-year parts and one-year labor warranty, installation start-up and performance check-up after one year from installation.

Main features

- Two 10.5 gallon tanks.
- 9-position energy regulator.
- 3-position water fill regulator.
- Constant water level refill.
- Automatic starch removal function during cooking: improved water quality over time.
- Automatic low-water level shut-off: no accidental over-heating.
- Electrolux Platinum Star® Service package included:
 - 2-year parts, 1-year labor warranty, 5-year compressor warranty.
 - Start-up install check.
 - Equipment check-up after 12 month from installation.

Construction

- Pressed 10.5 gal tanks: only rounded corners for improved cleanability.
- AISI 316 stainless steel tank: maximum corrosion resistance.
- All stainless steel construction.
- IPX 5 water jet protection (NEMA 4 equivalent).

Included Accessories

- 5" long, height adjustable legs.

Optional Accessories

- Bulk cooking basket.
- 2 of 1/2 size bulk cooking baskets.
- 3 of 1/3 size bulk cooking baskets.
- 3 of round individual-portion baskets.
- False bottom for round individual-portion baskets.
- Castors.



Approval: _____

Electrolux Professional, Inc.

www.electroluxusa.com/professional

3225 SW 42nd Street, Fort Lauderdale, Florida, 33312 • Telephone Number: 866-449-4200 • Fax Number: 954-327-6789

 Electrolux

Pasta Solutions
Free-standing, Double-well Pasta Cooker – Electric

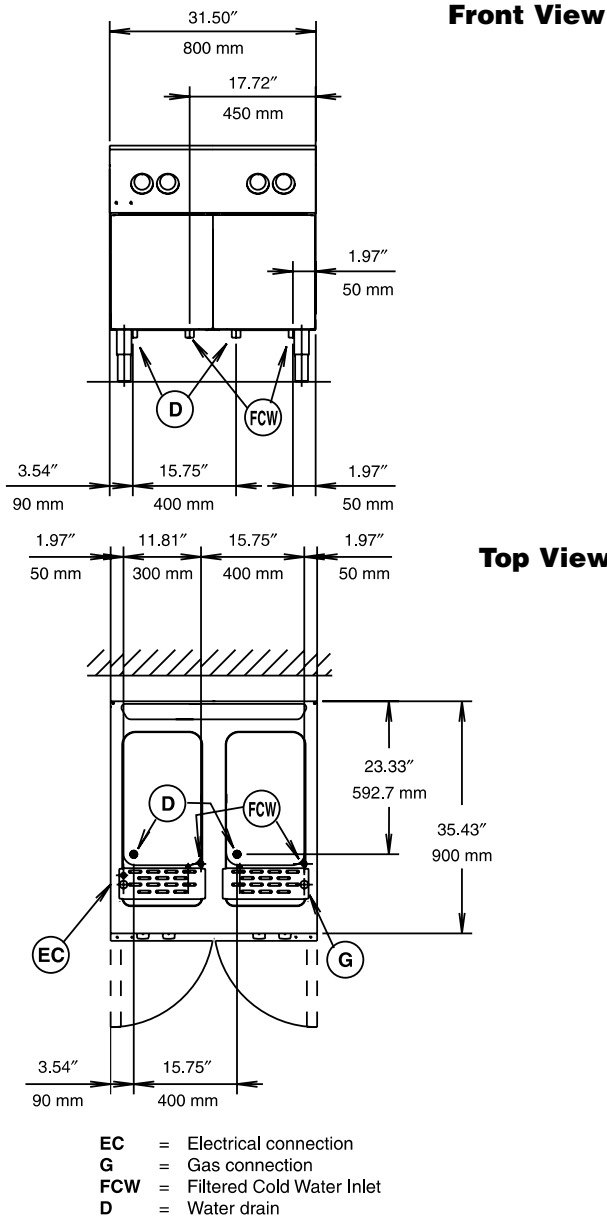

Electric

Supply voltage:

391204 (E9PCEH2MF2) 208 V/3p/60z - 56 A

Connected load:

20 kW

Water

Water inlet "CW" – 3/4" connection:

Total hardness: 5-50 ppm

Drain "D" 1" connection

Electrolux recommends the use of treated water, based on testing of specific water conditions.

Please refer to user manual for detailed water quality information.

Installation

Clearance: 4" (10 cm) from back.

Capacity

Max.: 2 x 10.5 gal

Min.: 2 x 8.5 gal

Key Information

Net weight: 254 lbs. (115 kg)

Height, inch/mm: 33-7/16" (849 mm)

Width, inch/mm: 31-1/2" (800 mm)

Depth, inch/mm: 35-7/16" (900 mm)

Shipping weight: 301 lbs. (140 kg)

Shipping width: 34.5" (880 mm)

Shipping height: 44.1" (1120 mm)

Shipping depth: 41" (1040 mm)

Shipping volume: 36.37 cu. ft. (1.03 m³)