



# High Productivity Cooking Gas Tilting Pressure Braising Pan 40 Gallons

ITEM # \_\_\_\_\_  
 MODEL # \_\_\_\_\_  
 PROJECT NAME # \_\_\_\_\_  
 SIS # \_\_\_\_\_  
 AIA # \_\_\_\_\_



## High Productivity Cooking Gas Tilting Pressure Braising Pan 40 Gallons

583402 (GX5HOE0000) Gas Tilting Pressure Braising Pan  
40 gallon 120 V

### Short Form Specification

Item No. \_\_\_\_\_

Unit to be Electrolux Gas Tilting Pressure Braising Pan 40 gallon capacity. Unit shall have polished chromium nickel steel plated cooking surface for roasting, browning, stewing, preparation of sauces, pressure cooking, sautéing, steaming, boiling, pressureless steaming, pressure steaming and braising. Unit shall be floor mounted on two consoles with four adjustable stainless steel feet. Unit shall include motorized variable tilting of pan and fully insulated and counterbalanced closing lid with safety closing mechanism. Cooking temperature and cooking time can be precisely set through state of the art control panel. Food sensor temperature built into base plates permits precise temperature cooking. Cooking times reduced thanks to cooking under saturated steam pressure of 5.8 psi.

Half-day chef training included.

Covered by Electrolux Platinum Star® Service Program two-year parts and one-year labor warranty, installation start-up and performance check-up after one year from installation.



Approval: \_\_\_\_\_

### Main features

- Pressure braising tilting pan with polished chrome nickel plated bottom (316 stainless steel). Thickness of bottom 7/10" inch plated with 3/25" inch stainless steel.
- Low energy and space requirements.
- Roasting, pot-roasting, braising, simmering, boiling, pressure cooking and steaming.
- 5.8 psi of saturated steam pressure.
- The bottom remains free of distortion and cracks even due to cold water quenching.
- Double –skin structure of both panels and lid to reduce heat dispersion.
- Lid includes safety mechanism when cooking under pressure. Lid cannot be opened when under pressure for safety.
- Actual cooking/holding temperature setting and digital display.
- Timer with digital display.
- Built in food temperature sensor for precise control of cooking process (bottom of pan or in vessel when lid is closed).
- An electronic microprocessor control system with digital pre-selection of food cooking temperature, cooking time, starting time and automatic pressure nullification by steam condensation.
- Robust burner with electronic ignition and monitoring as standard.
- Automatic detection of boiling or braising cycle.
- "Frying" operating mode with temperature over 230° F.
- "Cooking" operating mode with temperature equal or lower than 230° F.
- A SOFT setting for a gentle heat input, for delicate products thus avoiding undesired spillage.
- A HOLD setting where the food is initially cooked then held at a pre-set temperature.
- Cooking with a pressure of 5.8 psi reduces cooking-times by approximately 40%.
- Heat-insulated: limited heat radiation and low energy consumption.
- Motorized and variable tilting. Tilting and pouring speeds can be precisely adjusted.
- Offset tilting axle for convenient pouring height.
- Large directional pouring lip.
- Added safety: external heat-insulated paneling.
- Smooth large surfaces, easy access for cleaning.
- All pan internal surfaces ground and polished.
- Pan tilts over 90° for complete emptying/cleaning.

### Optional Accessories

- Suspension frame for hotel or half size pan.
- Base plate for hotel or half size pan.



High Productivity Cooking  
Gas Tilting Pressure Braising Pan 40 Gallons

**Electrolux Professional, Inc.**

[www.electroluxusa.com/professional](http://www.electroluxusa.com/professional)

10200 David Taylor Drive, Charlotte, NC 28262 • Telephone Number: 866-449-4200 • Fax Number: 704-547-7401

**Front View**

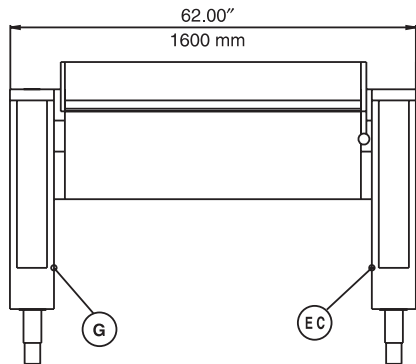

**Top View**

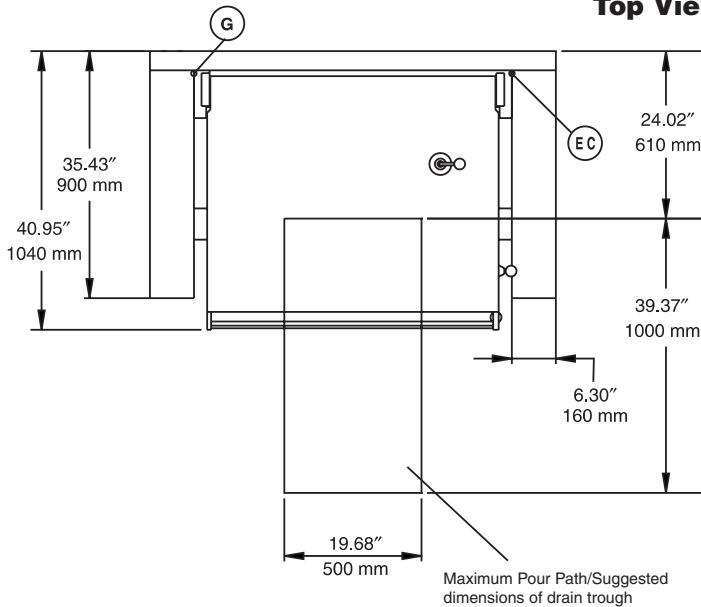

EC = Electrical connection  
G = Gas connection

**Side View**

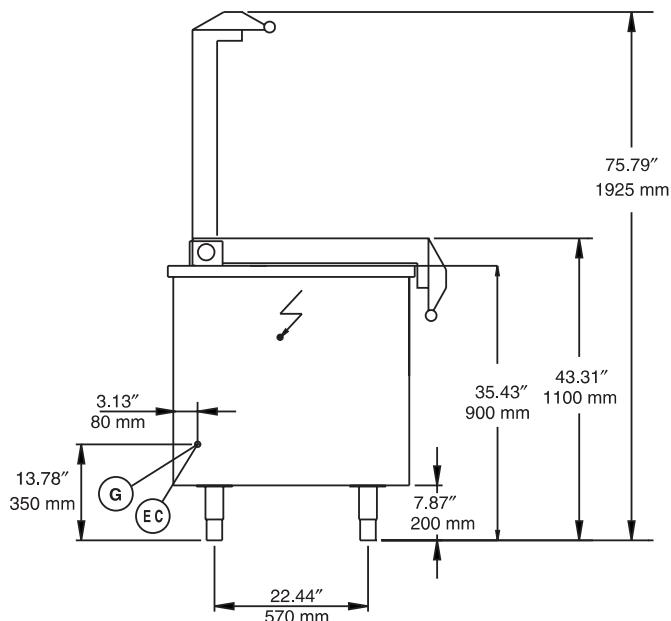

### Electric

**Supply voltage:**  
583402 (GX5H0E0000) 120 V/1p/60Hz - 0.7A  
**Total Watts:** 0.2 kW

### Gas

**Gas Power:** 98861 Btu/hr / 29 kW  
**Gas Type Option:** Butane, Natural Gas, Propane (must be specified when ordered)  
**Gas Inlet:** 1" NPT  
**Natural Gas Pressure:** 7" w.c. (17.7 mbar)  
**LPG Gas Pressure:** 11" w.c. (27.7 mbar)

### Key Information

**Distance to floor of pouring lip when tilted:** 19-1/16" (485 mm)  
**Saturated Steam pressure:** 5.8 psi (0.4 bar) MAX  
**Working Temperature:** 120 °F (50 °C) MIN  
482 °F (250 °C) MAX  
**Pan useful capacity:** 38.31 gal (145 liters)  
**Width of Pan:** 39" (990 mm)  
**Height of Pan:** 11-7/16" (290 mm)  
**Depth of Pan:** 19-5/16" (490 mm)  
**Net weight:** 750 lb (340 kg)  
**Shipping weight:** 794 lb (360 kg)  
**Shipping width:** 70-7/8" (1800 mm)  
**Shipping height:** 43-5/16" (1100 mm)  
**Shipping depth:** 47-1/4" (1200 mm)  
**Shipping volume:** 84.039 cu.ft ( 2.38 m3)

No clearance needed on rear or sides of unit if wall is of non-combustible type. If wall is combustible, minimum 6" (150 mm) wall clearance should be maintained.

Water fill faucet/shower to be mounted close to unit for filling and cleaning (not supplied).