

Electrolux

Modular Cooking Range Line S90 Heavy Duty 4-Burner Gas Range on Gas Oven C-Board

ITEM # _____

MODEL # _____

PROJECT NAME # _____

SIS # _____

AIA # _____



Modular Cooking Range Line S90 Heavy Duty 4-Burner Gas Range on Gas Oven C-Board

584108 (WGGWDFQ00) S90 4 Open Gas Burners
(34,000 BTU), gas oven,
c-board, 1 side operation

Short Form Specification

Item No. _____

Unit to be Electrolux S90 Heavy Duty four 34,000 BTU (10 kW) burner gas range with heavy duty 24,000 BTU (7 kW) standard gas oven. High efficiency burners with continuous power regulations from 7,500 BTU (2.2 kW) "simmering" to high power of 34,000 BTU's (10 kW). Thermocouples as standard on burners and oven for added safety. Unit to have raised rear c-board for against the wall or back to back unit installation. Body and oven of unit entirely in 304 stainless steel. Pan supports in heavy duty cast iron. Unit shall have heavy duty 304 stainless steel internal frame with reinforcement on the top of 0.157" (4 mm). Extra strength work top in heavy duty 0.118" (3 mm) stainless steel. "Lasertec" connection system permits units to be connected to each other creating a seamless work top.

Covered by Electrolux Platinum Star® Service Program two-year parts and one-year labor warranty, installation start-up and performance check-up after one year from installation.



Approval: _____

Main features

- The four 4" (100 mm) diameter 34,000 BTU (10 kW) high efficiency burners suit high performing cooking requirements for the most demanding customers.
- Manual gas valves with fixed high and low positions allow precise control of the flame intensity. Simmering as low as 7,500 BTU's (2.2 kW).
- Large sized pan support in cast iron (stainless steel as option) with long center fins to allow the use of the largest down to the smallest pans.
- Base compartment consists of a gas heated standard oven with gas fired burner for base heat. Ovens equipped with one stainless steel grid and one enameled baking tray.
- 24,000 BTU (7 kW) gas oven is with thermostatic valve and thermocouple safety device.
- Oven temperature up to 644 °F (340 °C).
- Thick steel base plate in the oven for an even temperature distribution and storage.
- Flat deep drawn spillage area with cleaning openings on front and rear side, with removable pan supports, burner rings and flame ignition parts.
- Gas main valve built as standard.
- Heavy duty internal frame 304 type stainless steel with reinforcement on top of 0.157" (4 mm).
- 0.118" (3 mm) top in 305 type stainless steel.
- "Lasertec connection system" creates seamless work top when units are connected to each other.
- Raised rear c-board permits unit to be connected up against the wall for better hygiene.
- Unit delivered with four 7-7/8" (200 mm) legs as standard (all round stainless steel plinth as option).

Optional Accessories

- Set 4 castors (2 with brake).
- 2.3" (60 mm) diameter burners with power regulation from 5,000 BTU (1.5 kW) to 20,500 BTU (6 kW).
- Simmering plate.
- Left side stainless steel 0.118" (3 mm) panel.
- Right side stainless steel 0.118" (3 mm) panel.
- 5" (130 mm) portioning shelf.
- 7.8" (200 mm) portioning shelf.
- All round stainless steel kick plates.

Electrolux Professional, Inc.

www.electroluxusa.com/professional

10200 David Taylor Drive, Charlotte, NC 28262 • Telephone Number: 866-449-4200 • Fax Number: 704-547-7401



Electrolux

S90 Heavy Duty 4-Burner Gas Range on Gas Oven C-Board
Modular Cooking Range Line



Modular Cooking Range Line S90 Heavy Duty 4-Burner Gas Range on Gas Oven C-Board

Front View

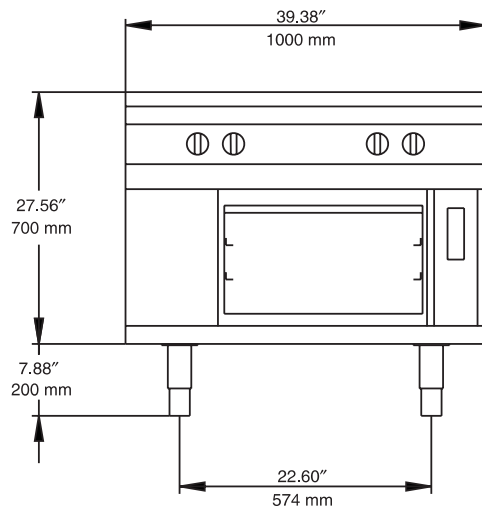

Top View

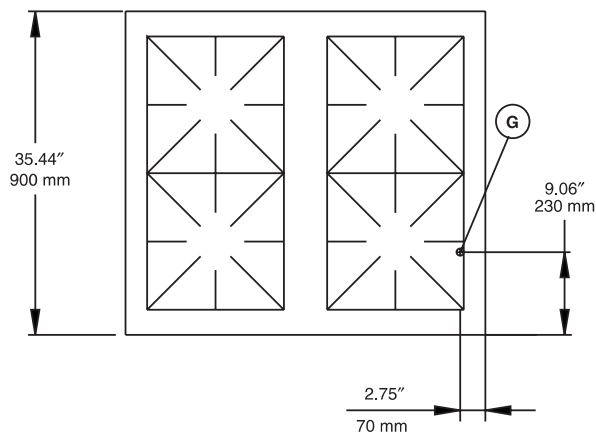

G = Gas connection

Side View

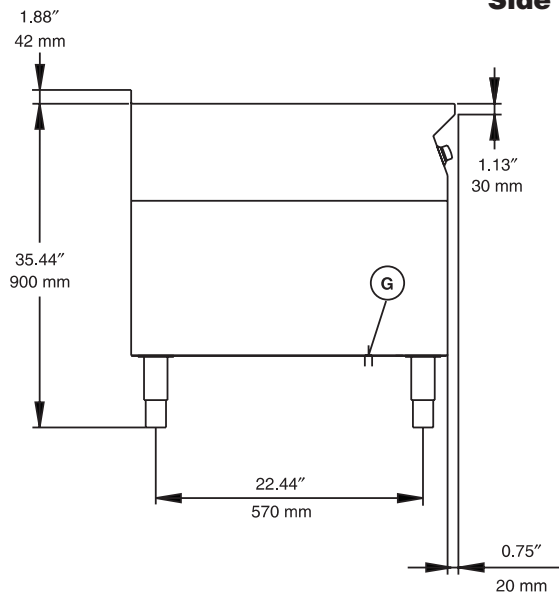

Gas

Gas Power:	163,000 Btu/hr (47.6 kW)
Gas Type Option:	Butane, Natural Gas, Propane (must be specified when ordered)
Natural Gas Pressure:	7" w.c. (17.7 mbar)
LPG Gas Pressure:	11" w.c. (27.7 mbar)
Gas Inlet:	3/4" NPT

Key Information

Oven working Temperature:	212 °F (100°C) MIN 644 °F (340°C) MAX
----------------------------------	--

Oven Cavity Dimensions (width):	21-5/8" (550 mm)
--	------------------

Oven Cavity Dimensions (height):	10-5/8" (270 mm)
---	------------------

Oven Cavity Dimensions (depth):	27-9/16" (760 mm)
--	-------------------

Net weight:	353 lb (160 kg)
--------------------	-----------------

Shipping weight:	397 lb (180 kg)
-------------------------	-----------------

Shipping width:	47-1/4" (1200 mm)
------------------------	-------------------

Shipping height:	43-5/16" (1100 mm)
-------------------------	--------------------

Shipping depth:	43-5/16" (1100 mm)
------------------------	--------------------

Shipping volume:	51.2 cu.ft (1.45 m ³)
-------------------------	-----------------------------------

If appliance is set up or next to or against temperature sensitive furniture or similar, a safety gap off approximately 6" (150 mm) should be maintained or some form of heat insulation fitted.

Modular Cooking Range Line
S90 Heavy Duty 4-Burner Gas Range on Gas Oven C-Board

The company reserves the right to make modifications to the products without prior notice. All information correct at time of printing.