

Electrolux

Modular Cooking Range Line S90 Electric Solid Top on Electric Oven, Island, 1 Side

ITEM # _____

MODEL # _____

PROJECT NAME # _____

SIS # _____

AIA # _____



Modular Cooking Range Line S90 Electric Solid Top on Electric Oven, Island, 1 Side

584152 (WLWWCAO00C) S90 Electric Solid Top,
Electric Oven, Island,
1 Side Operation – 208 V

Short Form Specification

Item No. _____

Unit to be Electrolux S90 Heavy Duty Electric Solid Top on Electric Oven. Electrical characteristics to be ____ 208 V three phase. Unit to be installed in central island type installations with operations from one side. Unit shall have joint-free large cooking surface with 4 heating areas with individual temperature settings for each zone from as low as 212 °F (100 °C) to as high as 842 °F (450 °C). Large flat cooking surface made of mild steel permits the use of a number of various sized pots and pans, all easily moved across the surface without lifting. Body and open base of unit entirely in 304 stainless steel. Unit shall have heavy duty 304 stainless steel internal frame. Extra strength worktop in heavy duty 0.118" (3 mm) stainless steel. "Lasertec" connection system permits units to be connected to each other creating a seamless worktop.

Covered by Electrolux Platinum Star® Service Program two-year parts and one-year labor warranty, installation start-up and performance check-up after one year from installation.



Approval: _____

Main features

- Unit for island type installation with operation by chef from one side (nobs only on one side of the console).
- 4 high powered heating electric zones.
- Solid top made of mild steel, smooth pore-free and easy to clean.
- 4 heating zones independently controlled.
- Surface temperature can be regulated with two power levels up to 842 °F (450 °C) for a very high degree of accuracy.
- Joint-free large cooking surface.
- Rapid heat up of the plate and continuously ready for use.
- Setting different temperature zones provides a temperature gradient over the plate for different cooking needs.
- Various sizes of pans can be used at the same time due to large surface area with no intermediate sectors.
- Pans can easily be moved from one area to another without lifting.
- Base compartment consists of an electric heated standard oven for base heat. Ovens equipped with one stainless steel grid and one enameled baking tray.
- Oven temperature up to 644 °F (340 °C).
- Thick steel base plate in the oven for an even temperature distribution and storage.
- Heavy duty internal frame in 304 type stainless steel.
- Control parts are protected against water and heat.
- All major components can be accessed from the front for ease of maintenance.
- "Lasertec connection system" creates seamless worktop when units are connected to each other.
- Unit delivered with four 7-7/8" (200 mm) legs as standard (all round stainless steel plinth as option).

Optional Accessories

- Set of 4 castors (2 with brakes)
- Left side stainless steel 0.118" (3 mm) panel
- Right side stainless steel 0.118" (3 mm) panel
- 5" (130 mm) portioning shelf
- 7.8" (200 mm) portioning shelf
- All round stainless steel plinth
- Shelf for open base
- Shelf fixation kit for open base
- Polinox steel wool for solid top cleaning

Electrolux Professional, Inc.

www.electroluxusa.com/professional

10200 David Taylor Drive, Charlotte, NC 28262 • Telephone Number: 866-449-4200 • Fax Number: 704-547-7401



Electrolux

Modular Cooking Range Line
S90 Electric Solid Top on Electric Oven, Island, 1 Side

Front View

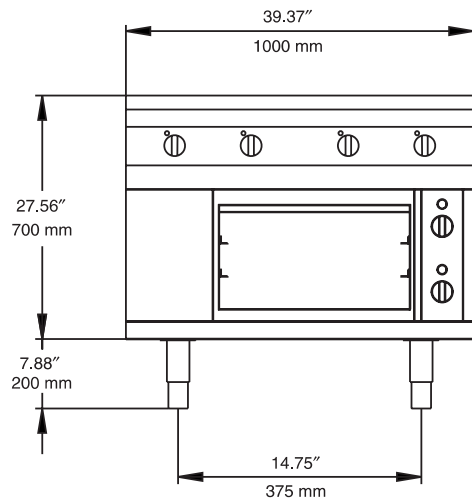

Top View

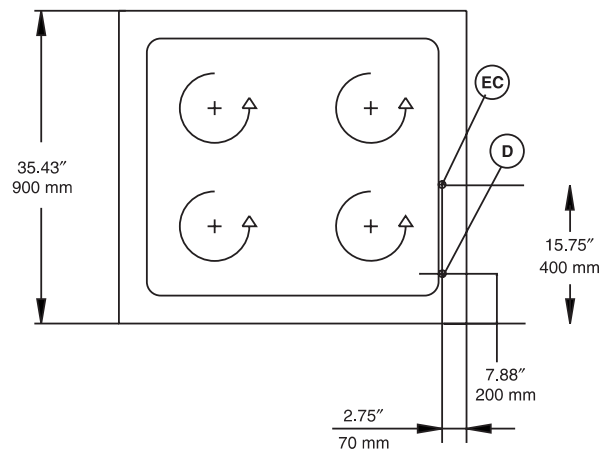

EC = Electrical connection
D = Water drain

Side View

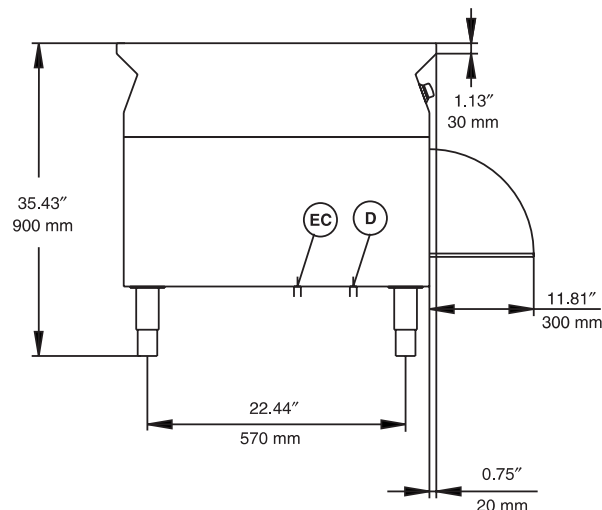

Electric

Supply voltage:

584152 (WLWWCA000C) 208 V/3p/60Hz - 51.7A

Total Watts:

584152 (WLWWCA000C) 17.8 kW

Drain

Drain Line Size: 1" ID

Drain only for draining of dirty water used for cleaning top burners spillage area.

Key Information

Solid top usable surface (width): 30" (840 mm)

Solid top usable surface (depth): 29" (740 mm)

Solid top working temperature: 212 °F (100 °C) MIN

Solid top working temperature: 842 °F (450 °C) MAX

Oven working Temperature: 212 °F (100 °C) MIN
644 °F (340 °C) MAX

Oven Cavity Dimensions (width): 21-5/8" (550 mm)

Oven Cavity Dimensions (height): 10-5/8" (270 mm)

Oven Cavity Dimensions (depth): 27-9/16" (760 mm)

Net weight: 485 lb (220 kg)

Shipping weight: 529 lb (240 kg)

Shipping width: 47-1/4" (1200 mm)

Shipping height: 43-5/16" (1100 mm)

Shipping depth: 43-5/16" (1100 mm)

Shipping volume: 51.2 cu.ft (1.45 m³)

If appliance is set up or next to or against temperature sensitive furniture or similar, a safety gap off approximately 6" (150 mm) should be maintained or some form of heat insulation fitted.