

# Electrolux

## Modular Cooking Range Line S90 Gas Solid Top on Gas Oven, Island, 1 Side

ITEM # \_\_\_\_\_

MODEL # \_\_\_\_\_

PROJECT NAME # \_\_\_\_\_

SIS # \_\_\_\_\_

AIA # \_\_\_\_\_



### Modular Cooking Range Line S90 Gas Solid Top on Gas Oven, Island, 1 Side

584161 (WLGWDA0000) S90 Gas Solid Top, gas oven,  
island, 1 side operation

### Short Form Specification

Item No. \_\_\_\_\_

Unit to be Electrolux S90 Heavy Duty 52,000 BTU (15.3 kW) Gas Solid Top with heavy duty 24,000 BTU (7 kW) standard gas oven. Unit to be installed in central island type installations with operations from one side. Unit shall have joint free large cooking surface with 2 heating areas with individual temperature settings for each zone from as low as 212 °F (100 °C) to as high as 842 °F (450 °C). Large flat cooking surface made of mild steel permits the use of a number of various sized pots and pans, all easily moved across the surface without lifting. Thermocouples as standard on oven for added safety. Body and open base of unit entirely in 304 stainless steel. Unit shall have heavy duty 304 stainless steel internal frame. Extra strength work top in heavy duty 0.118" (3 mm) stainless steel. "Lasertec" connection system permits units to be connected to each other creating a seamless work top.

Covered by Electrolux Platinum Star® Service Program two-year parts and one-year labor warranty, installation start-up and performance check-up after one year from installation.

### Main features

- Unit for island type installation with operation by chef from one side (nobs only on one side of the console).
- Gas heated, 52,000 BTU (15.3 kW) burners, solid top.
- Solid top made of mild steel, smooth pore-free and easy to clean.
- 2 heating zones independently controlled.
- Surface temperature can be regulated with two power levels up to 842 °F (450 °C) for a very high degree of accuracy.
- Joint free large cooking surface.
- Rapid heat up of the plate and continuously ready for use.
- Setting different temperature zones provides a temperature gradient over the plate for different cooking needs.
- Various sizes of pans can be used at the same time due to large surface area with no intermediate sectors.
- Pans can easily be moved from one area to another without lifting.
- Base compartment consists of a gas heated standard oven with gas fired burner for base heat. Ovens equipped with one stainless steel grid and one enameled baking tray.
- 24,000 BTU (7 kW) Gas oven is with thermostatic valve and thermocouple safety device.
- Oven temperature up to 644 °F (340 °C).
- Thick steel base plate in the oven for an even temperature distribution and storage.
- Heavy duty internal frame in 304 type stainless steel.
- Control parts are protected against water and heat.
- All major components can be accessed from the front for ease of maintenance.
- "Lasertec connection system" creates seamless work top when units are connected to each other.
- Unit delivered with four 7-7/8" (200 mm) legs as standard (all round stainless steel kick plates as option).

### Optional Accessories

- Set 4 castors (2 with brake).
- Stainless steel 0.118" (3 mm) side panel.
- 5" (130 mm) portioning shelf.
- 7.8" (200 mm) portioning shelf.
- All round stainless steel kick plates.
- Polinox steel wool for solid top cleaning.



Approval: \_\_\_\_\_

**Electrolux Professional, Inc.**

[www.electroluxusa.com/professional](http://www.electroluxusa.com/professional)

10200 David Taylor Drive, Charlotte, NC 28262 • Telephone Number: 866-449-4200 • Fax Number: 704-547-7401



# Electrolux

Modular Cooking Range Line  
S90 Gas Solid Top on Gas Oven, Island, 1 Side



## Modular Cooking Range Line S90 Gas Solid Top on Gas Oven, Island, 1 Side

**Front View**

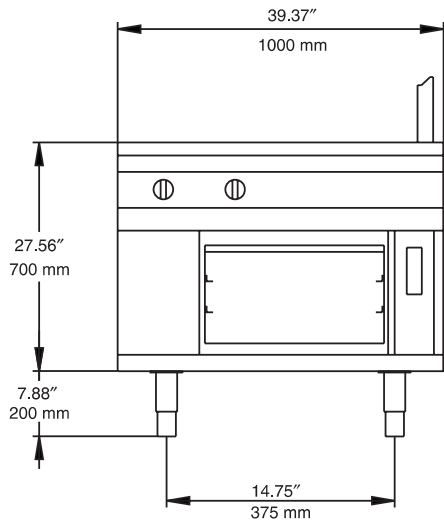

**Top View**

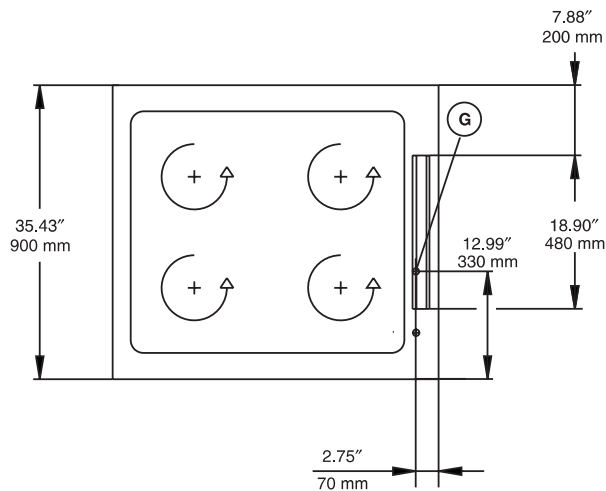

G = Gas connection

**Side View**

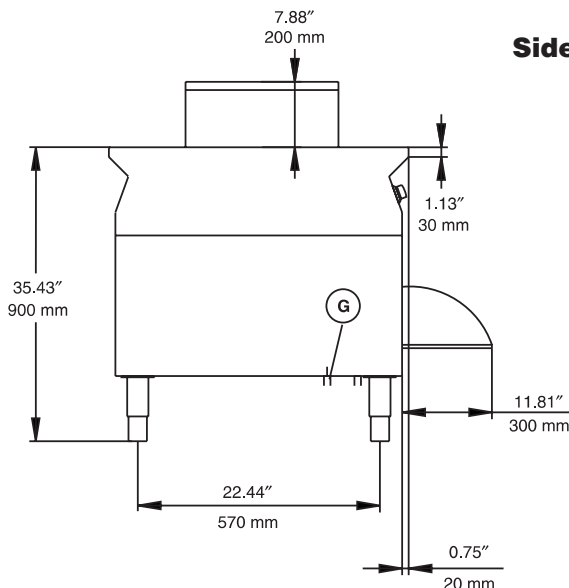

### Gas

<b>Gas Power:</b>	78,000 Btu/hr (22.9 kW)
<b>Gas Type Option:</b>	Butane, Natural Gas, Propane (must be specified when ordered)
<b>Natural Gas Pressure:</b>	7" w.c. (17.7 mbar)
<b>LPG Gas Pressure:</b>	11" w.c. (27.7 mbar)
<b>Gas Inlet:</b>	3/4" NPT

### Key Information

<b>Solid top usable surface (width):</b>	30" (840 mm)
<b>Solid top usable surface (depth):</b>	29" (740 mm)
<b>Solid top working temperature:</b>	212 °F (100 °C) MIN
<b>Solid top working temperature:</b>	842 °F (450 °C) MAX
<b>Oven working Temperature:</b>	212 °F (100 °C) MIN
	644 °F (340 °C) MAX

<b>Oven Cavity Dimensions (width):</b>	21-5/8" (550 mm)
<b>Oven Cavity Dimensions (height):</b>	10-5/8" (270 mm)
<b>Oven Cavity Dimensions (depth):</b>	27-9/16" (760 mm)
<b>Net weight:</b>	507 lb (230 kg)
<b>Shipping weight:</b>	551 lb (250 kg)
<b>Shipping width:</b>	47-1/4" (1200 mm)
<b>Shipping height:</b>	43-5/16" (1100 mm)
<b>Shipping depth:</b>	43-5/16" (1100 mm)
<b>Shipping volume:</b>	51.2 cu.ft (1.45 m <sup>3</sup> )

If appliance is set up or next to or against temperature sensitive furniture or similar, a safety gap off approximately 6" (150 mm) should be maintained or some form of heat insulation fitted.

Modular Cooking Range Line  
S90 Gas Solid Top on Gas Oven, Island, 1 Side

The company reserves the right to make modifications to the products without prior notice. All information correct at time of printing.